

ENTERPRISES, INC.

HOWELL

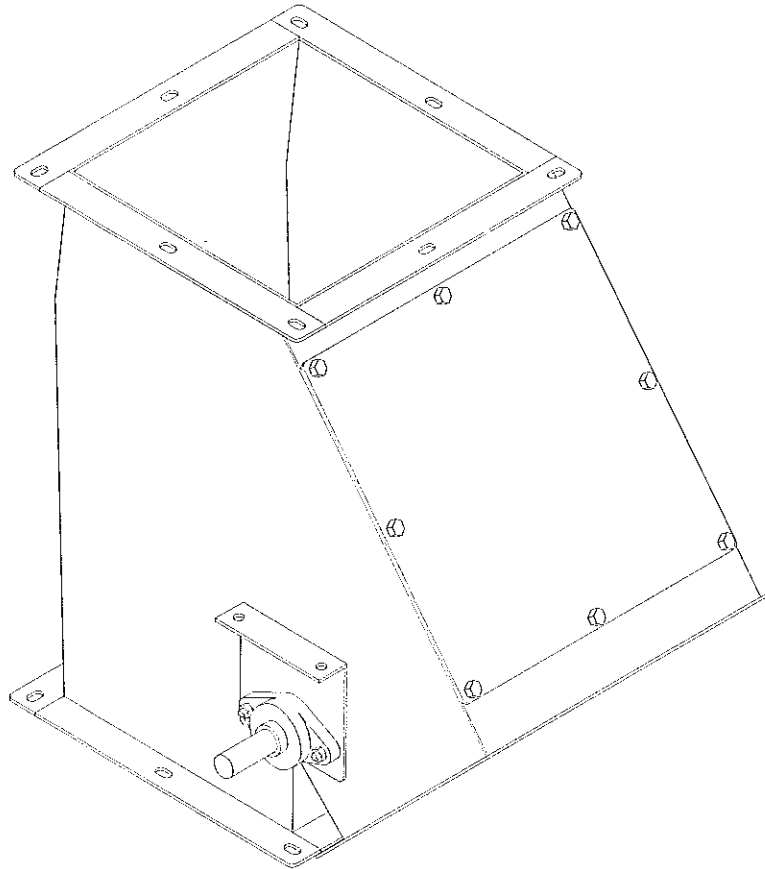

**FLOPPER VALVE
GENERAL INFORMATION**

INSTALLATION ■ OPERATION ■ MAINTENANCE

2013

Identifying the specific piece of equipment is important when making inquiries regarding installation, operation, maintenance, warranty or parts. A record for each piece of equipment is kept on file at S-M Enterprises, Inc. When contacting your dealer, please have the following information available.

Valve Information

	ORDER #
	<input type="text"/>
	MANUFACTURE DATE
	<input type="text"/>
MODEL #	<input type="text"/>

This information may be obtained from the item packing slip or the serial tag located on the side of the valve.

Table of Contents

	Page
<u>Introduction</u>	2
<u>Inspecting and Verifying the Shipment</u>	3
<u>Valve Parts Identification</u>	4
<u>Safety Guidelines</u>	5
<u>Safety Decals</u>	6
<u>Safety Decal Locations</u>	7
<u>Electrical</u>	8
<u>Initial Startup</u>	10
<u>Maintenance</u>	14
<u>Trouble Shooting</u>	17
<u>Warranty</u>	19
<u>Andco Linear Actuator</u>	Appendix 1



2310 26th St South
Moorhead, MN 56560

Phone (218) 236-5050
(800)245-9148
Fax (218) 233-6378

Introduction

Thank you for choosing Howell products. This manual is designed to assist you in the operation, safety and maintenance of our flopper valves. All installers, operators and maintenance personnel are encouraged to read this manual.

All valves have either a 1" or 1 1/4" drive shaft that pivots on 2 bolt flange bearings. The door seal is made from 3/16" neoprene rubber. An inspection door is standard on all valves.

Valves can be ordered manufactured from heavier wear resistant materials than standard if requested.

There are 4 different types of drive systems:

Manual Operation

This can be operated manually by hand or with a cable system. Consider that it may be difficult to manually operate large valves. This kind of valve can easily be converted to an electric right angle gearbox with a conversion kit.

Electric Right Angle Gearbox

This is the most common electric valve and can use either a TEFC or IIG motor. The gearbox will be provided with an Overload Safety Device Clutch to help prevent damage to the gearbox. A Double-Pole Double-Throw limit switch will be provided. This switch functions as the door limit for either direction.

Linear Actuated Gate

This is an electrically actuated cylinder that attaches to a lever on the valve door. The actuator has internal limit switches.

Air Actuated Gate

This is an air cylinder that attaches to a lever on the valve door and runs off compressed air. This comes with the solenoid that is mounted to the side of the valve. The cylinder is pre-plumbed to the solenoid. One Double-Pole Double-Throw limit switch to indicate fully open and fully closed can be provided upon request.

Inspecting and Verifying the Shipment

All of the components have been carefully inspected for quality and quantity prior to shipping and re-checked during the shipping process. The customer is responsible for verifying the condition of all the parts as they are received. If any visual damage exists, it will need to be reported to the shipping carrier and noted on the "Bill of Lading". The manufacturer's responsibility for damage ends with the acceptance of the shipping carrier. The manufacturer needs to be notified of damage if any replacement parts are needed.

This shipment also needs to be verified for proper quantity as listed on the packing list. Locate all the components listed on the packing list, checking them off as they are found. Notify S-M Enterprises, Inc if anything is missing or any damage is found.

VALVE PART IDENTIFIER

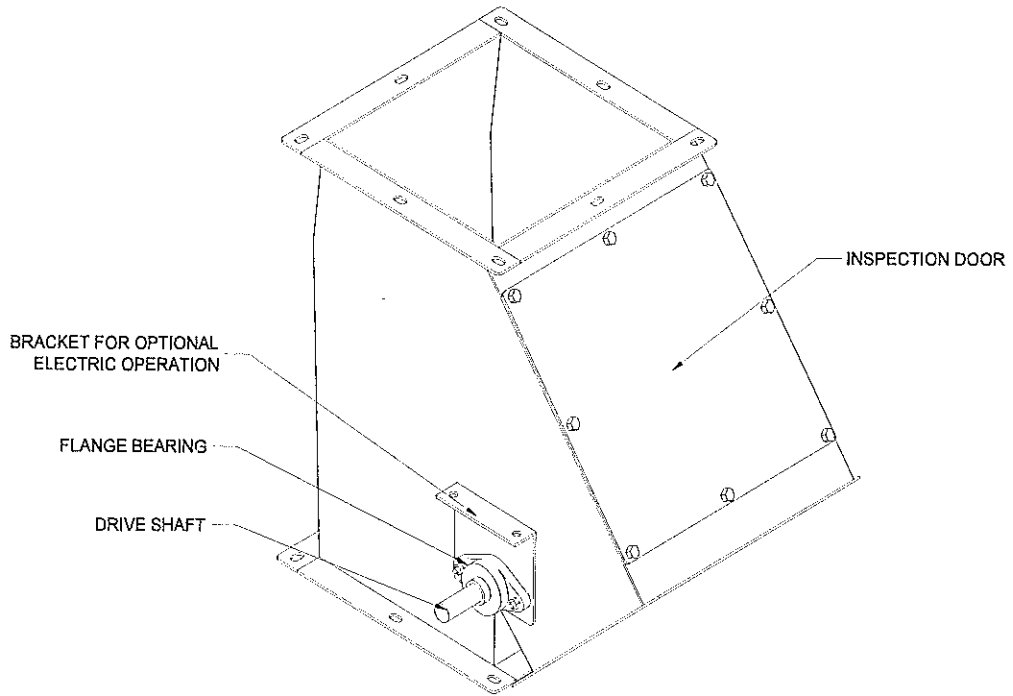

Figure 1

Safety Guidelines

It is important that this manual be read by the owner and operator. It contains important safety information that must be followed and understood to prevent serious injury or death. It is the responsibility of the owner/operator to inform anyone who is operating or working in the area of the equipment of these safety guidelines. Failure to read this manual and follow the safety guidelines is a misuse of the equipment and may lead to serious injury or death.



THIS IS A SAFETY ALERT SIGN. IT IS USED TO HELP IDENTIFY SAFETY HAZARDS THAT COULD INJURE OR KILL IF NOT AVOIDED.



DANGER: Indicates an imminently hazardous situation which, if not avoided, will result in death or serious injury.



WARNING: Indicates an potentially hazardous situation which, if not avoided, will result in death or serious injury.



CAUTION: Indicates an potentially hazardous situation which, if not avoided, may result in minor to moderate injury.

Responsibilities

1. Valves shall not be operated unless all covers and/or guards for the unit are in place. If the valve is to be opened for inspection, cleaning, maintenance or observation, all electrical power must be LOCKED OUT in such a manner that it cannot be restarted by anyone.
2. Do not attempt any maintenance or repairs of the equipment until power has been locked out.
3. Always operate equipment in accordance with these instructions and those contained on the caution labels affixed to the equipment.
4. Do not place hands, feet or any part of your body in the equipment.
5. Do not attempt field modification of equipment or components.

It is the responsibility of the owner/ operator to know what requirements, precautions and specific hazards exist and make these known to all personnel working with the equipment or in the area. Do not be limited to these safety rules.

Safety Decals

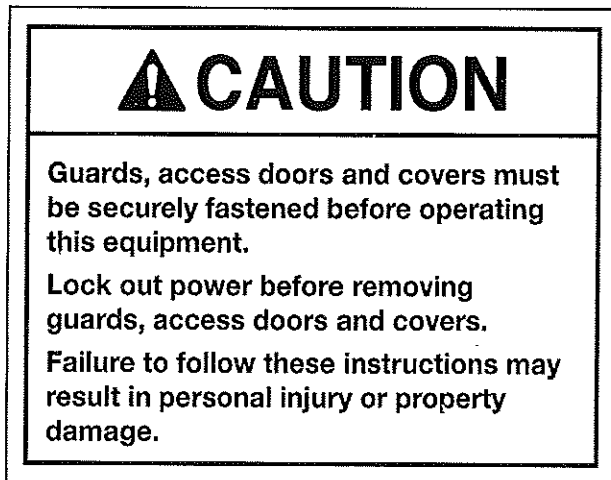

Tag 13

Safety decals have been placed on the valve. Do not remove, deface or paint over them. If any labels are missing or damaged in any way, contact S-M Enterprises, Inc. for replacements.

Safety decals should be read and understood by everyone.

See Figure 2 for location information.

VALVE WARNING LABEL LOCATIONS

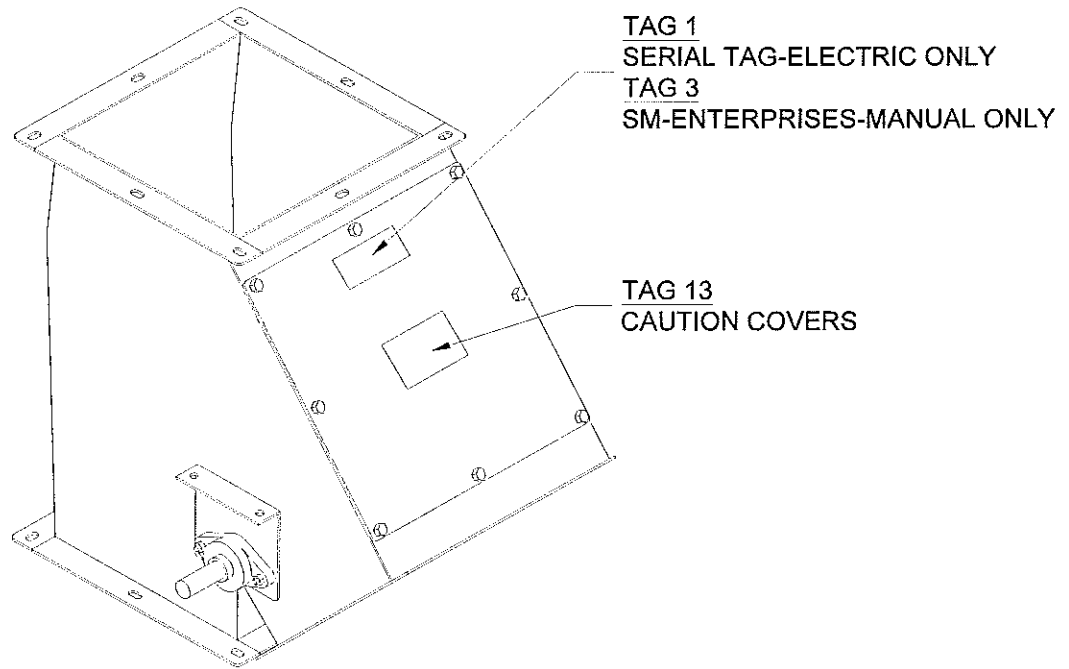

Figure 2

Electrical

Electrical must be done by a qualified electrician in accordance with all applicable electrical codes. Check local codes before installation.

Figures 3 and 4 are typical wiring diagrams for electric right angle gearbox setup.

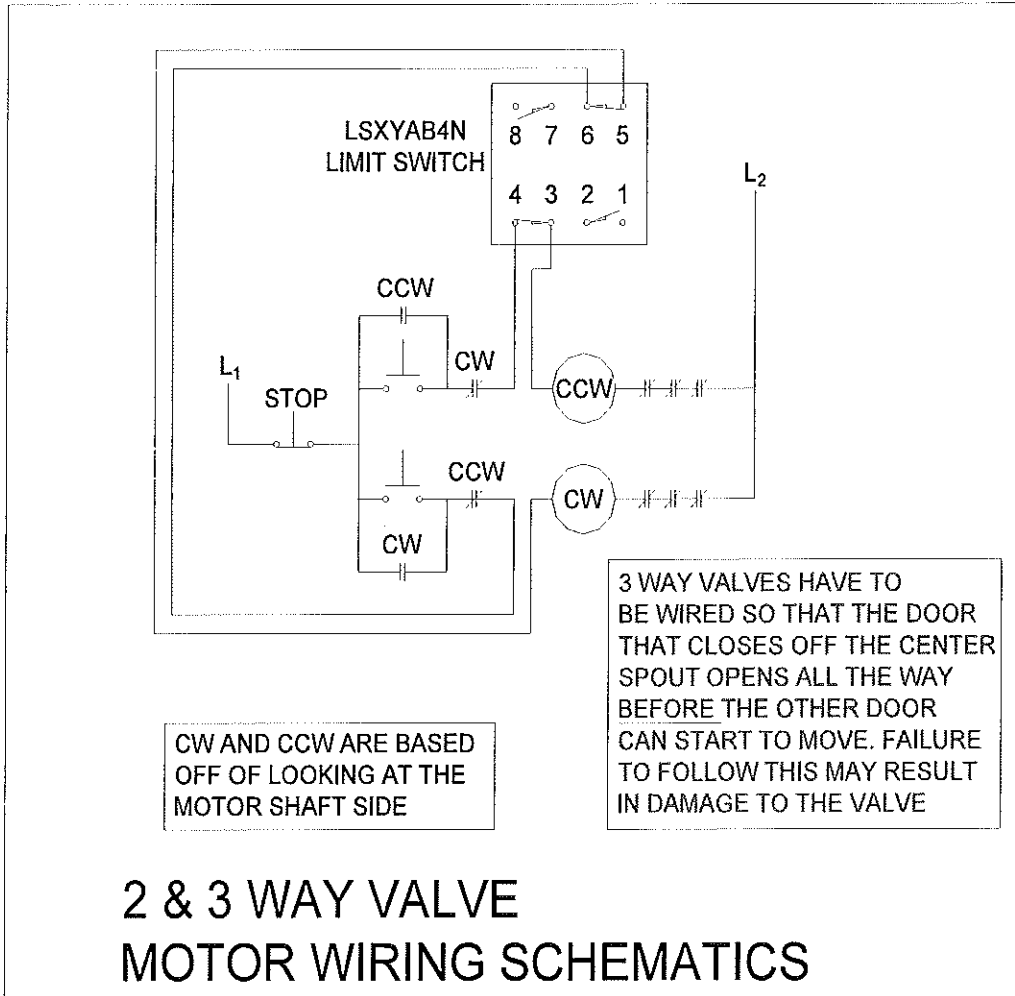

Figure 3

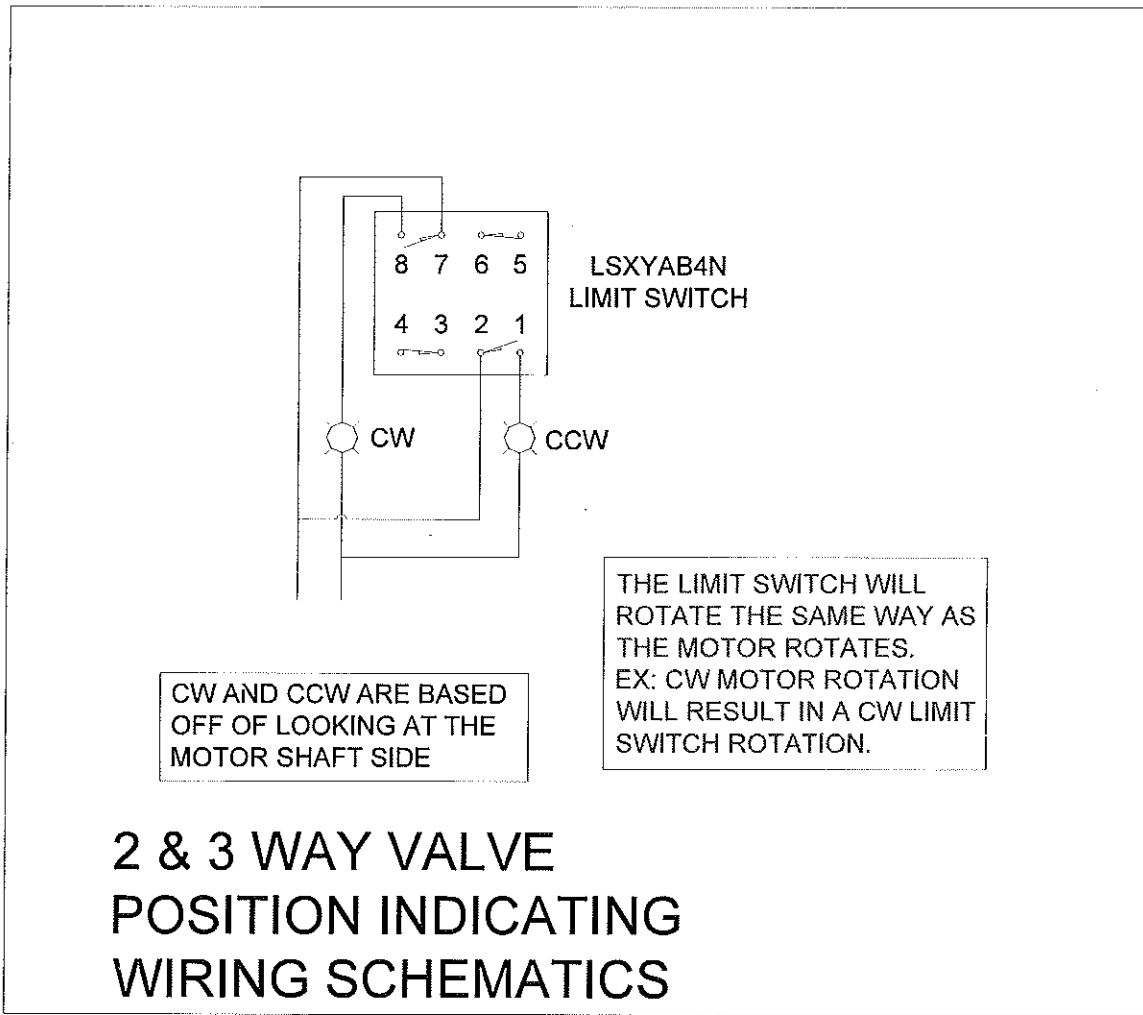

Figure 4

See Appendix 1 for a typical wiring diagram for Andco linear actuator.

See Figure 6 for the Air Cylinder Solenoid wiring and plumbing diagram.

Initial Startup

Electric Right Angle Gearbox

The gearbox and limit switch will ship factory mounted. The motor is not installed on gearbox nor is the limit switch pre set.

The Double-Pole Double-Throw switch functions for both directions. To set the limit switch start by pointing the arm toward the drive shaft centered between the two halves of the dial. Loosen the (2) set screws that are in the shaft collars of the dial along with the (1) 5/16" locking bolt. Move the door all the way to one side and then rotate the dial toward the tripper arm until the limit switch 'clicks' then tighten up the set collar screw on that half of the dial. Flip the door the opposite way. Turn the second half of the dial toward the tripper arm until the limit switch "clicks" then tighten up the set collar screw on the second half of the dial. Now tighten the 5/16" bolt that connects the two halves together. See Figure 5. Test and make sure that the door operates in both directions stopping before it bottoms out. It is important that it does not bottom out as it will wear the clutch down.

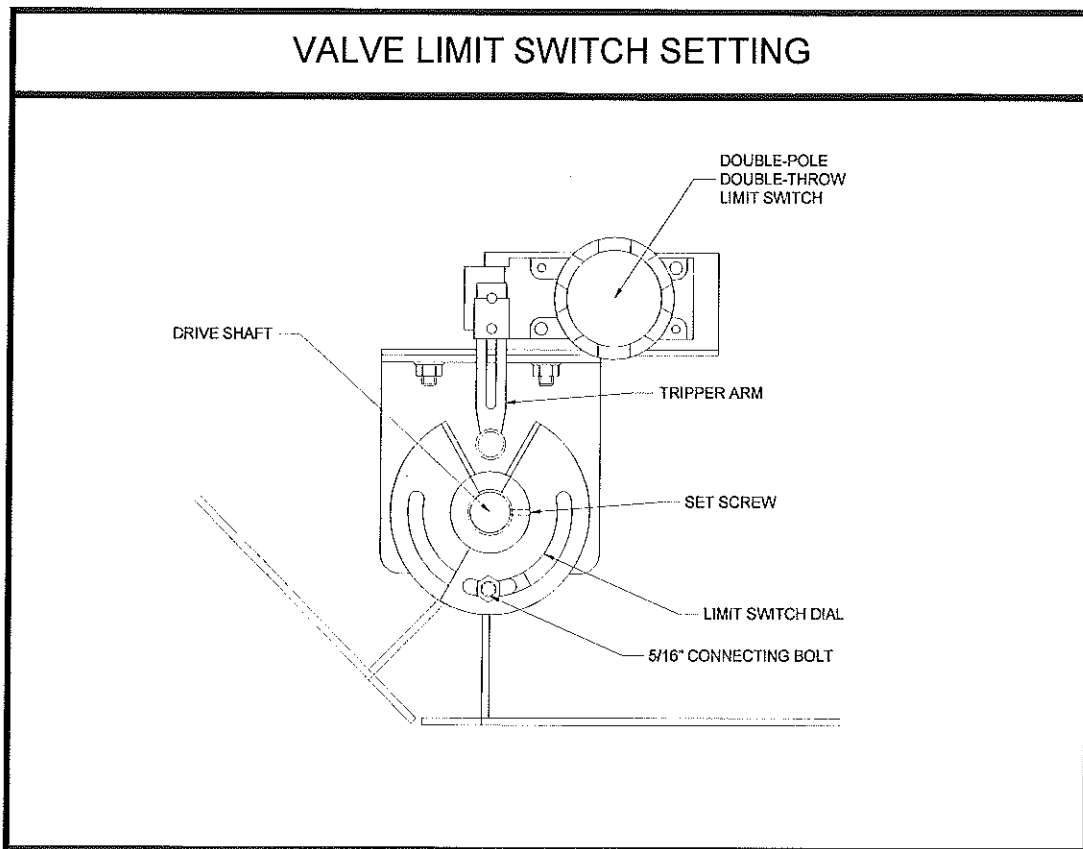

Figure 5

We use two standard types of drive setups depending on what the valve torque requirements are:

1. Dodge Size 17 Gearbox with a 7.5 to 1 Ratio Multiplier and a Dalton Overload Safety Device Clutch.

2. Dodge Size 20 Gearbox with a 7.5 to 1 Ratio Multiplier and a Dalton Overload Safety Device Clutch

Both kinds of gearboxes are shipped filled with synthetic oil. The oil level in the gearbox is figured so the gearbox can be installed anywhere from horizontal to 45 degrees as long as the motor is running upward not downward. If the valve is installed outside of this range consult the gearbox manufacturer's instructions to determine the proper oil fill. See the maintenance section of this manual for the oil type specs.

Linear Actuated Valve

The Actuator is factory mounted. The customer needs to check the internal limit switches prior to running it. These may or may not be set at the factory and damage could occur if they are not set properly. Review the Andco manual (Appendix 1) for setting these switches. The Andco manual has a lot of good information about the actuator.

Air Actuated Valve

The air cylinder and the solenoid are factory provided and mounted. It will also be plumbed from the solenoid to the cylinder. The solenoid will have to be wired and supplied with compressed air. Decide what position the flopper door needs to be, in the event of a power failure. This can be changed by reversing the solenoid output lines that connect to the cylinder. See Figure 5.

Air valves do not always work well in cold weather. The solenoid commonly freezes up because of moisture in the lines. If possible move it inside to a warm environment. An adequate dryer system will also help prevent moisture from entering the lines.

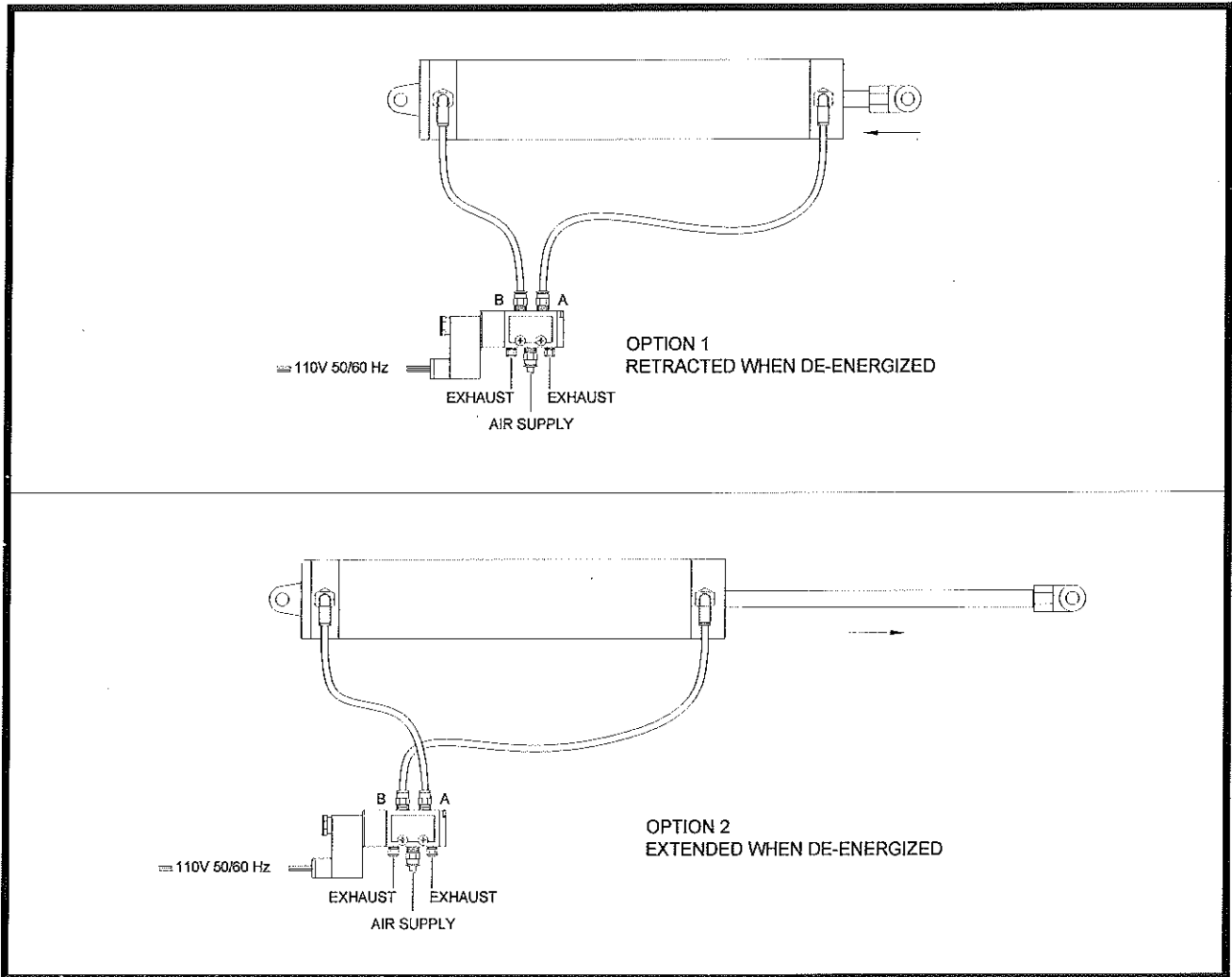
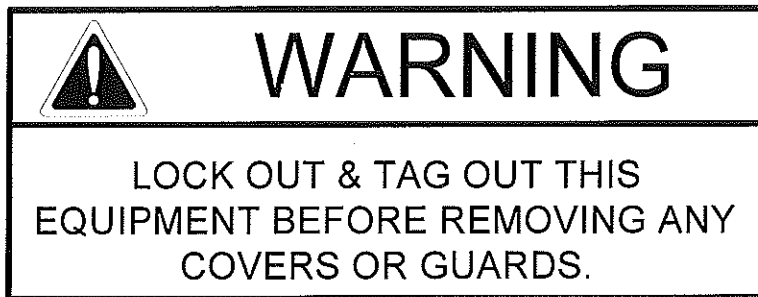

Figure 6

Maintenance



Valves do not require much maintenance.

Periodically test the flopper door to ensure that it is moving without any restrictions. Noises or difficulty moving the slide may indicate that something is rubbing or hanging up inside the valve.

It is recommended that the drive shaft bearings, if equipped, be inspected and greased once every 12 months or so depending on its use.

The Overload Safety Device Clutch is not designed to slip during normal operating conditions. They are designed to prevent damage to the gearbox in case of an unusual event. If the clutch does start to slip, determine what is causing it to do so. The most common cause is a limit switch that is incorrectly set causing the door to "overrun". The other main cause is that there may be some sort of obstruction making it difficult or impossible for the door to operate. Note that a flopper valve will not operate very well with flowing product. Either way the problem will need to be corrected. Continued operation like this will wear the clutch disc down and it will have to be retightened or replaced.

Dodge Size 17 Gearbox with a 7.5 to 1 Ratio Multiplier and a Dalton Overload Safety Device Clutch

The Dodge Gearbox does not require any maintenance. It is factory filled with synthetic oil that is expected to last the life of the gearbox. The oil must be purchased from a Dodge representative.

The Ratio Multiplier is factory mounted onto the gearbox. It is also factory filled with Mobil SHC 634 synthetic oil and does not require any maintenance when used with a valve due to the low service factor.

The Dalton Clutch Coupler has been factory torqued at 100 ft/lbs and should not require regular maintenance. If adjustment is needed, start by locking out the power to the gearbox. Then remove the coupler guard by removing the (2) 5/16" bolts that attach the guard to the gearbox mount. See Figure 7 to adjust clutch. Loosen the (2) 1/8" set screws that lock the large adjustment nut. Using the factory supplied 2 1/8" wrench turn the nut clockwise. It can be adjusted up to 125 ft/lbs. Adjusting the slip coupler any tighter than 125 ft/lbs renders it useless and gearbox damage may occur. Retighten the (2) locking set screws and reinstall the coupler guard.

Dodge Size 20 Gearbox with a 7.5 to 1 Ratio Multiplier and a Dalton Overload Safety Device Clutch

The Dodge Gearbox does not require any maintenance. It is factory filled with synthetic oil that is expected to last the life of the gearbox. The oil must be purchased from a Dodge representative.

The Ratio Multiplier is factory mounted onto the gearbox. It is also factory filled with Mobil SHC 634 synthetic oil and does not require any maintenance when used with a valve due to the low service factor.

The Dalton Clutch Coupler has been factory torqued at 125 ft/lbs and should not require regular maintenance. If adjustment is needed, start by locking out the power to the gearbox. Then remove the coupler guard by removing the (2) 5/16" bolts that attach the guard to the gearbox mount. See Figure 7 to adjust clutch. Loosen the (2) set screws that lock the large adjustment nut. Using the factory supplied wrench turn the nut clockwise. It can be adjusted up to 175 ft/lbs. Adjusting the slip coupler any tighter than 175 ft/lbs renders it useless and gearbox damage may occur. Retighten the (2) locking set screws and reinstall the coupler guard.

COUPLER ADJUSTMENT

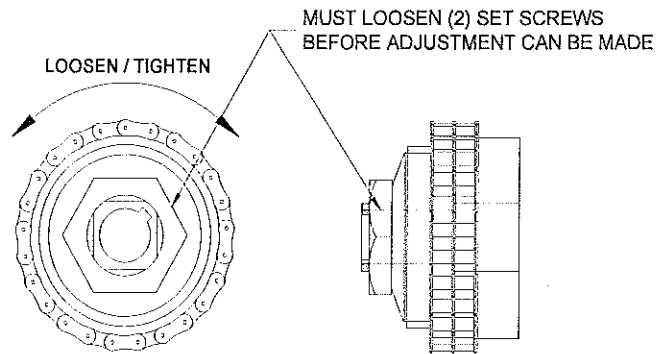

DALTON COUPLER
USED WITH DODGE GEARBOX

Figure 7



WARNING

LOCK OUT & TAG OUT THIS
EQUIPMENT BEFORE REMOVING ANY
COVERS OR GUARDS.

Trouble Shooting

If you are having trouble with electric or air operated valves seizing up, then it is a good idea to disconnect the drive and try moving the door manually. Depending on the size of the valve the door itself may be very difficult to move but it should be possible. If you cannot manually move the door, see below 'flopper does not operate easily'. If the door is functional then work thru the other Trouble Shooting sections.

Problem	Possible Cause	Solutions
flopper does not operate or is stuck	<p>full of product</p> <p>foreign object stuck in valve</p> <p>seals too tight</p>	<p>a flopper valve will not operate well unless the product flow is shut off before attempting to flip the door</p> <p>open the inspection cover and check for anything that may be lodged in the valve</p> <p>the rubber dust seals inside the valve are too tight on the sides of the door they can wear in with time otherwise they may need to be trimmed.</p>
electric right angle gearbox gate does not operate	<p>clutch is loose</p> <p>bad gearbox</p> <p>bad motor</p>	<p>tighten the clutch see maintenance section for instructions figure 7</p> <p>check and repair or replace</p> <p>check and repair or replace</p>
Andco linear actuator gate does not operate	<p>see appendix 1 for Andco trouble shooting guide</p>	

Trouble Shooting Cont

Problem	Possible Cause	Solutions
air gate does not operate	plumbing damaged bad solenoid freezing temps	check for leaks and repair test and replace air gates may not work well in the cold see 'initial startup' section

LIMITED WARRANTY

S-M Enterprises, Inc., hereinafter referred to as "S-M" warrants each S-M Enterprises product to be free from defects in material and workmanship, when used under normal use and service conditions, for a period of twelve (12) months commencing on the date of delivery of the complete product. The "defect" must be reported to S-M, or to S-M's representative within this 12 month warranty period.

THIS LIMITED WARRANTY IS MADE EXPRESSLY IN LIEU OF ALL OTHER WARRANTIES, WHETHER EXPRESSED OR IMPLIED INCLUDING, BUT NOT LIMITED TO, WARRANTIES OF MERCHANTABILITY AND FITNESS FOR A PARTICULAR PURPOSE, AND ALL OTHER OBLIGATIONS OR LIABILITIES ON THE PART OF S-M. THE CUSTOMERS RIGHTS AND REMEDIES ARE GOVERNED EXCLUSIVELY BY THE TERMS AND CONDITIONS OF THIS LIMITED WARRANTY, AND CUSTOMER EXPRESSLY WAIVES FOR HIMSELF AND ANY PURCHASER, ANY CLAIM BASED UPON CONTRACT, NEGLIGENCE, TORT, STRICT LIABILITY OR OTHERWISE.

S-M's obligation and sole remedy under this warranty is exclusively limited, at S-M's option, to either repair or replace any part or product found to be defective, within a reasonable time, providing that such part or product is returned to S-M; factory in Moorhead, Minnesota, transportation charges prepaid, or to the selling dealer or distributors place of business from whom the purchase was made. The "defective" product or part may also be returned to the S-M's factory in Moorhead, Minnesota, transportation charges prepaid, for a full refund of the purchase price with respect to any failure of product due to defects in material or workmanship. All corrective work on S-M's product must be approved in writing by S-M prior to such repairs. No allowances will be made for corrective work that has been completed without this express approval. If S-M is unable to repair the equipment, S-M will, at its option: (a) replace the equipment, or (b) refund the purchase price. These remedies are the Buyer's exclusive remedies for breach of warranty. Any action for breach of warranty must be commenced within 15 months following delivery of the goods. S-M makes no warranties with respect to any equipment sold but not manufactured by S-M.

Improper lubrication, improper installation, deterioration by chemical action, and premature wear caused by the presence of abrasive materials do not constitute "defects".

THIS WARRANTY SHALL NOT RENDER S-M LIABLE FOR ANY CONSEQUENTIAL DAMAGES, INCLUDING AND WITHOUT LIMITATION, TO; PERSONAL INJURY, EXPENSES OF REMOVING THE PRODUCTS), LOSS OR DAMAGE RESULTING TO THE EQUIPMENT OR STRUCTURE(S) IN WHICH THE S-M'S PRODUCTS HAVE BEEN INSTALLED, LOSS OF USE OF SUCH EQUIPMENT OR STRUCTURE; LOSS OF COMMODITY, OR LOSS OF PROFITS. IN NO EVENT SHALL S-M BE LIABLE FOR MORE THAN THE PURCHASE PRICE OF THE EQUIPMENT IN THIS CONTRACT.

This warranty shall not apply to any S-M's products that have been altered, or repaired by anyone other than an authorized S-M's service representative, and any product that which has been subject to abuse, misuse, neglect, or accident, nor to any product which shall be found to have been installed or operated in accordance with the S-M's printed operators manual.

This warranty will be declared null and void immediately if the purchaser, a representative of the purchaser, or anyone else shall modify, install, or cause to be installed, replacement parts not sold, distributed, or approved by the S-M.

The equipment covered by this Agreement is capable of handling a wide variety of materials, including those that are flammable and/or explosive. As such, there may be a fire and explosion hazard. Fire and explosion detection and suppression systems vary depending on the materials being processed and handled. Thus, Buyer is solely responsible for and must determine what fire and explosion protection is necessary for its facility, including for the equipment covered by the agreement. Buyer must supply all necessary fire and explosion detection and suppression equipment or systems.

S-M is not an expert in the chemical and biological properties of the infinite number of materials that might be processed in or handled by the equipment covered by the Agreement. Before processing or handling any materials that are or can be flammable, explosive, toxic or otherwise hazardous, Buyer must perform a thorough process hazard analysis and risk assessment of its entire process, including contingency plans for dealing with processing errors and upset conditions.

Much of the equipment that S-M manufacturers can be fitted with a wide variety of options that could be used to reduce specific hazards created by the product which it handles, including, for example, explosion relief panels, electrically grounded components, the ability to maintain an inert atmosphere, and remote sampling and cleaning.

Unless specifically set out the Agreement, the equipment quoted does not contain these available safety features. Buyer shall be solely responsible for knowing or determining the hazards of its product and its process and for contacting S-M to learn about the availability of these safety features.

This warranty shall not be extended to gearboxes, motors, electrical controls, filters, or any purchased component that carries its own manufacturers warranty; the warranty on these products will be limited to the published warranties of their respective manufacturers.

All claims under this warranty are to be made, in writing, within 15 days of the date of failure to; S-M Enterprises, Inc., 2310 26th Street South, Moorhead, Minnesota 56560. Failure to do so will result in customers claim being waived.

S-M is not responsible for installation of the product, and is not liable for any loss or damage attributed to improper installation. Customer acknowledges that it is knowledgeable concerning the goods purchased; that customer has reviewed the limited warranty; and that the remedies provided are adequate to customer. S-M is not responsible or liable for any claim of personal injury or death. S-M neither assumes or authorizes any person to assume for S-M any other liabilities in connection with the sale of its products. This warranty is subject to existing conditions of supply which may directly effect the ability of the manufacturer to obtain materials or manufacturer replacement parts.

Customer agrees to incorporate the terms of this limited warranty into subsequent sale or transfer of these goods to a third party such that the S-M's liability shall be expressed, limited to the terms and conditions of this limited warranty as well as the choice of law and choice of jurisdiction provisions of this agreement. If any party brings an action against S-M for other than those set forth in this limited warranty, customer agrees to defend S-M against for other than those set forth in this limited warranty, customer agrees to defend S-M against such claims at customers expense, including attorney's fees, and to indemnify and hold S-M harmless against any such claims or judgments thereon. In no event shall S-M's liability extend beyond the terms of the warranty provided to S-M's original customer.

Customer agrees that Customer's rights and responsibilities in regard to this transaction shall be governed by the law of the State of Minnesota, and shall be exclusive jurisdiction for bringing any disputes in regard to this transaction, which must be venued in District Court, Clay County, Minnesota.

This writing constitutes the entire representations of warranties, oral or written, express or implied, statutory or otherwise. This limited warranty may be modified only in writing, signed and notarized by S-M, at its home office in Moorhead, Minnesota.