



Custom Conveyor
Corporation

The System Professionals

Belt Conveyors

*Not just one solution
- The right Solution.
A Total Material Handling
Solutions Supplier*





Designing & Manufacturing Belt Conveyors Since 1983

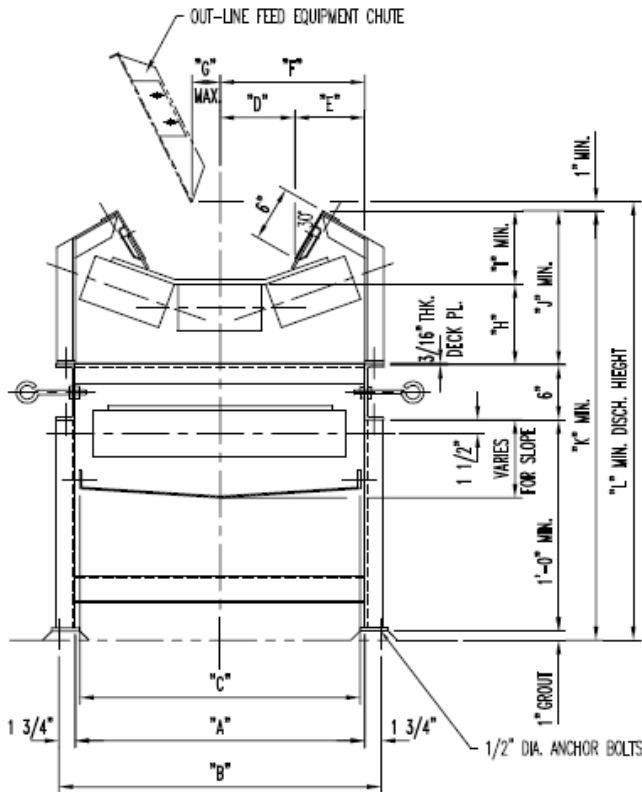

TYP. TROUGH BELT CROSS SECTION

CROSS SECTION DIMENSION CHART

ITEM	BELT WIDTH				
	18"	24"	30"	36"	42"
A	2'-1"	2'-7"	3'-1"	3'-7"	4'-1"
B	2'-4 1/2"	2'-10 1/2"	3'-4 1/2"	3'-10 1/2"	4'-4 1/2"
C	2'-0"	2'-6"	3'-0"	3'-6"	4'-0"
D	6"	8"	10"	1'-0"	1'-2"
E	6 1/2"	7 1/2"	8 1/2"	9 1/2"	10 1/2"
F	1'-0 1/2"	1'-3 1/2"	1'-6 1/2"	1'-9 1/2"	2'-0 1/2"
G	3"	3"	3"	4"	4"
H	8 3/4"	8 3/4"	8 3/4"	8 7/8"	9 3/16"
I	8"	8"	8"	8"	8"
J	1'-4 3/4"	1'-4 3/4"	1'-4 3/4"	1'-4 7/8"	1'-5 3/16"
K	2'-11 3/4"	2'-11 3/4"	2'-11 3/4"	2'-11 7/8"	3'-0 3/16"
L	3'-0 3/4"	3'-0 3/4"	3'-0 3/4"	3'-0 7/8"	3'-1 3/16"

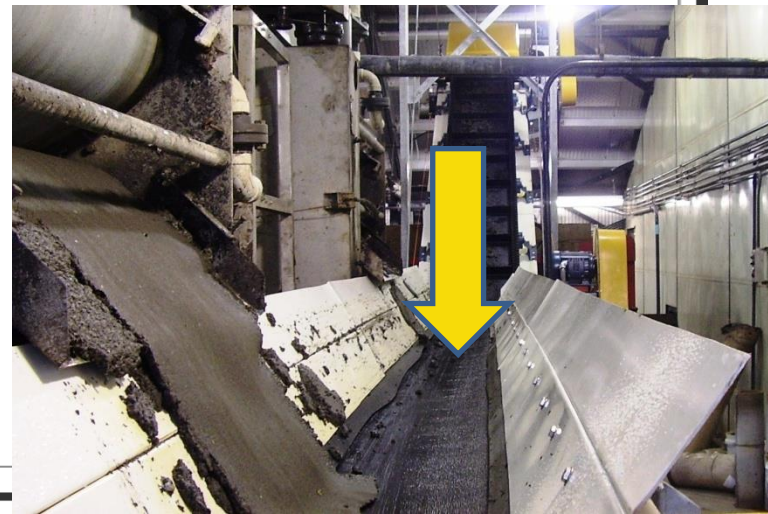



Custom Conveyor
Corporation

Conveyors Troughing Belt

Built to **CEMA** Standards

- **Dewatered sludge**
maximum 28° incline.
- **Screenings**
maximum 20° incline.
- **Grit**
maximum 20° incline.

Our troughed belt conveyors are designed specifically for each application and construction utilities the **highest quality** components and fabrication methods.



GRIT BELT CONVEYOR

Albuquerque, New Mexico



Custom Conveyor
Corporation

Conveyors Troughing Belt



SCREENINGS BELT
Bloomington, Illinois
Completely Enclosed & Insulated



FINE SCREENINGS
Sioux Falls, South Dakota
Fiberglass drive end guard



Custom Conveyor
Corporation

Conveyors Troughing Belt



VERTICAL CURVE
BELT FILTER PRESS SLUDGE
St. Paul, Minnesota



BELT FILTER PRESS SLUDGE
Tuscarora, Maryland



Conveyors Troughing Belt

Shuttle Belt Conveyors



Advantages:

- Can fill container evenly throughout
- Reversible
- Does not need multiple gates

Overhead view of **Commerce MI** system with four shuttle belt conveyors surrounded by a grated mezzanine.

Driven flanged wheels on rails and electrical festoons give the conveyors mobility.



Custom Conveyor
Corporation

Conveyors Troughing Belt

Radial Stacker Conveyor



Large radius storage stacker

- Creates continuous radial stacked pile
- Can feed one or multiple bins
- Can utilize sensors for automatic operation
- Motorized drive wheels
- Articulating option



Conveyors Troughing Belt Slider Bed Type

- Low Profile, < 25"
- No idler rollers
- Completely enclosed

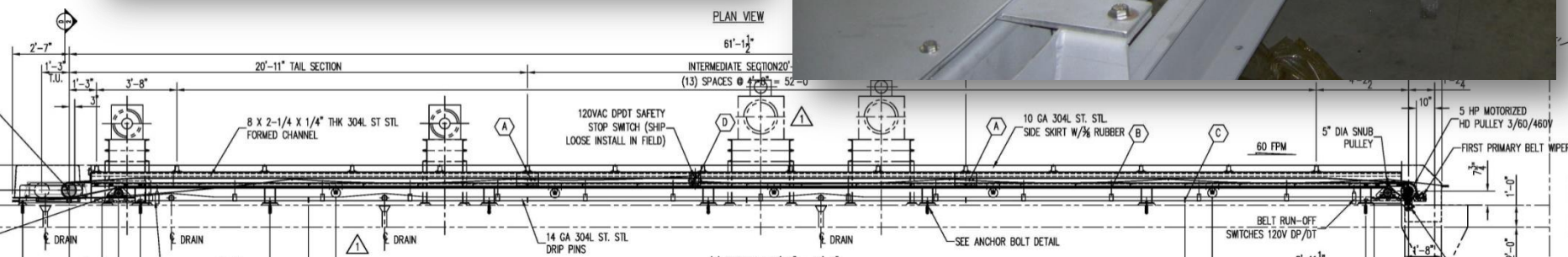
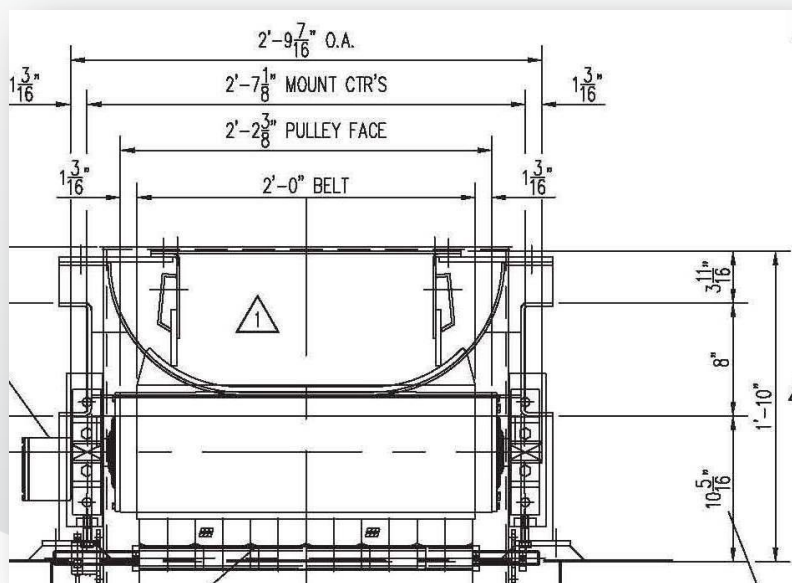



Multi - Plane Sidewall Belt

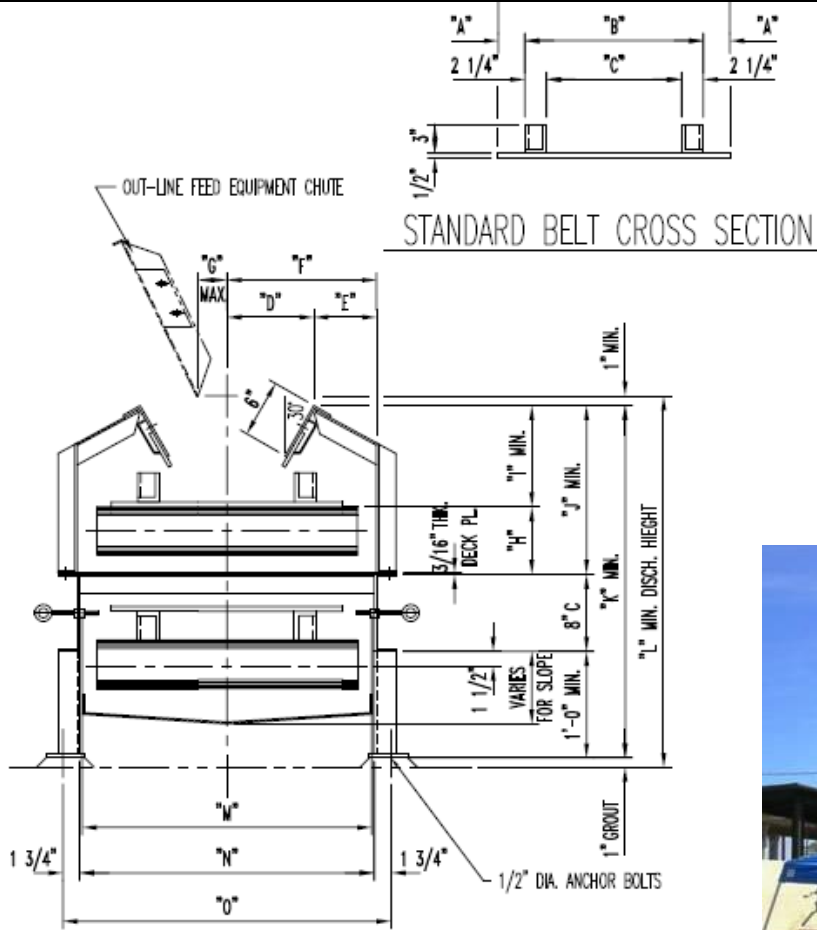

CROSS SECTION DIMENSION CHART

ITEM	BELT WIDTH				
	18"	24"	30"	36"	42"
A	2 3/4"	2 3/4"	3 1/4"	3 3/4"	4 1/2"
B	1'-0 1/2"	1'-6 1/2"	2'-0 1/2"	2'-6 1/2"	3'-0 1/2"
C	8"	1'-2"	1'-8"	2'-2"	2'-8"
D	5 3/4"	8 3/4"	11 3/4"	1'-2 3/4"	1'-5 3/4"
E	6 1/2"	6 1/2"	6 1/2"	6 1/2"	6 1/2"
F	1'-0 1/4"	1'-3 1/4"	1'-6 1/4"	1'-9 1/4"	2'-0 1/4"
G	3"	3"	3"	4"	4"
H	6 3/4"	6 3/4"	6 3/4"	6 3/4"	6 3/4"
I	10 3/4"	10 3/4"	10 3/4"	10 3/4"	10 3/4"
J	1'-5 1/2"	1'-5 1/2"	1'-5 1/2"	1'-5 1/2"	1'-5 1/2"
K	3'-1 1/2"	3'-1 1/2"	3'-1 1/2"	3'-1 1/2"	3'-1 1/2"
L	3'-3 1/2"	3'-3 1/2"	3'-3 1/2"	3'-3 1/2"	3'-3 1/2"
M	2'-0"	2'-6"	3'-0"	3'-6"	4'-0"
N	2'-0 1/2"	2'-6 1/2"	3'-0 1/2"	3'-6 1/2"	4'-0 1/2"
O	2'-4"	2'-10"	3'-4"	3'-10"	4'-4"





Multi-plane Sidewall Belt Conveyors



- allow versatile design options.

- Multiple planes with one drive
- 28° incline, up to 60° incline with cleats
- Robust construction
- Low power needs
- Low cost



Top: A sidewall multi-plane belt conveyor in Lowell IN conveys dewatered sludge to yard storage.

Left: A sidewall multi-plane belt conveys belt filter press sludge in Kearney NB.

Right: Adding cleats like this sidewall in Madison, IN allows sludge to be conveyed up to 60° incline.





SANDWICH BELT SLUDGE ELEVATORS

- were developed to eliminate the carry-over of a product caused by conventional cleated belts and thumper type belt cleaners. The sludge elevator achieves steep incline conveying of sludge. The primary belt is a flat belt, without cleats, allowing it to be cleaned by conventional belt cleaners.

- Up to 75° incline.
- Up to 40 feet of vertical lift.



Anamosa, Iowa



Lake Geneva, Wisconsin



Custom Conveyor
Corporation

Conveyors Belt Covers

Protect your Equipment and Product from the Environment

Conveyor belt covers are able to cover belts from 18" to 84" wide, on 3'-0" to 5'-0" centers. These systems can be manufactured in galvanized steel, aluminum, stainless steel, fiberglass and painted steel. We offer full coverage and $\frac{3}{4}$ coverage styles as standard.

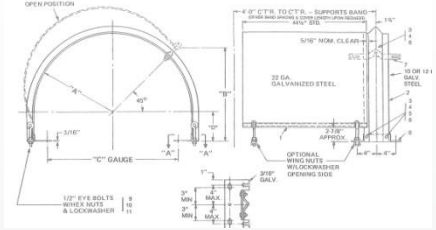

CH series is a full smooth cover and among the most economical full cover systems. These full covers are hinged with a retaining bar to allow the cover to be held in an open position.



CH-75 series is a $\frac{3}{4}$ stationary smooth cover. These covers allow coverage of the belt and are open 45 degrees, standard, for viewing at a glance. Hinges are optional.



CHCO series is a full corrugated cover. Perpendicular corrugations give these covers more rigidity. They are hinged for convenient viewing. $\frac{3}{4}$ stationary is an option.



CHLC series is a $\frac{3}{4}$ stationary corrugated cover. Great for the overland conveyor. The corrugations run parallel with the conveyor.



Standard CEMA components

+ many upgrades available only through CUSTOM

- **Motors** -TEFC Chemical Duty
- **Gear reducers**, Helical shaft mount
- **Drive end pulleys** 12" diameter with lagging
- **Roller bearings**, self aligning with protected screw take-ups
- **Belt covers**, mild oil resistant service (MORS)
- **Belt splice**, stainless steel mechanical & vulcanized
- **Idlers**, CEMA C 5" diameter, urethane coated
- **Frame and supports**, Hot dip galvanized, stainless steel (optional aluminum)
- **Skirt board** with neoprene seal strips, Fiberglass reinforced plastic
- **Belt scraper**, Neoprene spring tensioned
- **Drip pans**, Fiberglass reinforced plastic (CUSTOM design)
- **Belt cover return**, Fiberglass reinforced plastic (CUSTOM design)
- **Emergency stop switch**,
- **Zero speed switch**

CUSTOM offers many belt conveyor optional materials and devices -

- **Gates** – Clam, Knife, Diverter, Proportioning
- **Plows** - Side Discharge, Proportioning, Traveling
- **Belt Cleaning & Wash Systems**
- **Weigh Belts**
- **Structural Support**, Access Walkways & Stairs, Truss framework, Transfer Towers



Custom Conveyor
Corporation

Conveyor Value

Experience

Custom Conveyor Corp offers **30+ years** experience manufacturing in our own fully equipped facility. We are the industry Leader with 3000 installations and 100 miles of conveyors uniquely offering Versatility of the correct conveying solution for your application -

Belt Types = Troughing – Sidewall – Cleated – Sandwich

Quality

Custom Conveyor Corp continuously invests in the equipment and skilled staff for quality, product improvement and growth. We offer many proprietary conveyor components.

Reliability

Custom Conveyor Corp has thousands of trouble free installations. Many are operating 20+ years with original parts.

Custom Conveyor Corp - The System Professionals
Your Total Material Handling Solutions Supplier