

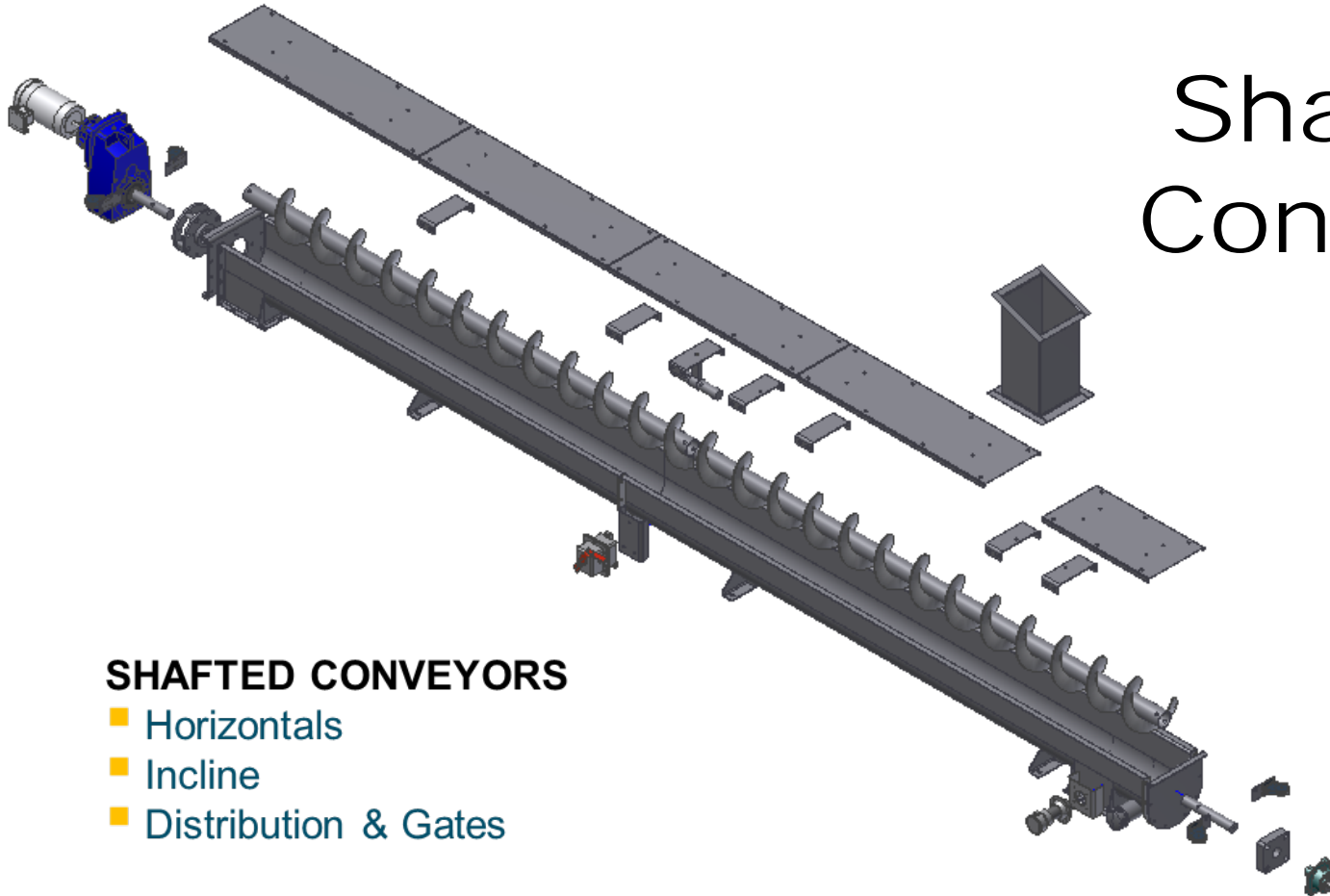

Custom Conveyor
Corporation

CUSTOM
CONVEYOR
CORP

Shafted Conveyors



SHAFTED CONVEYORS

- Horizontals
- Incline
- Distribution & Gates



Shafted Screw Waste Water Applications

Grit

- Underwater Grit Screws
- Dewatered Grit

Sludge

- Dewatered Sludge
- Dried Sludge
- Hopper Leveling Screw

Lime

- Feeders
- Mixers

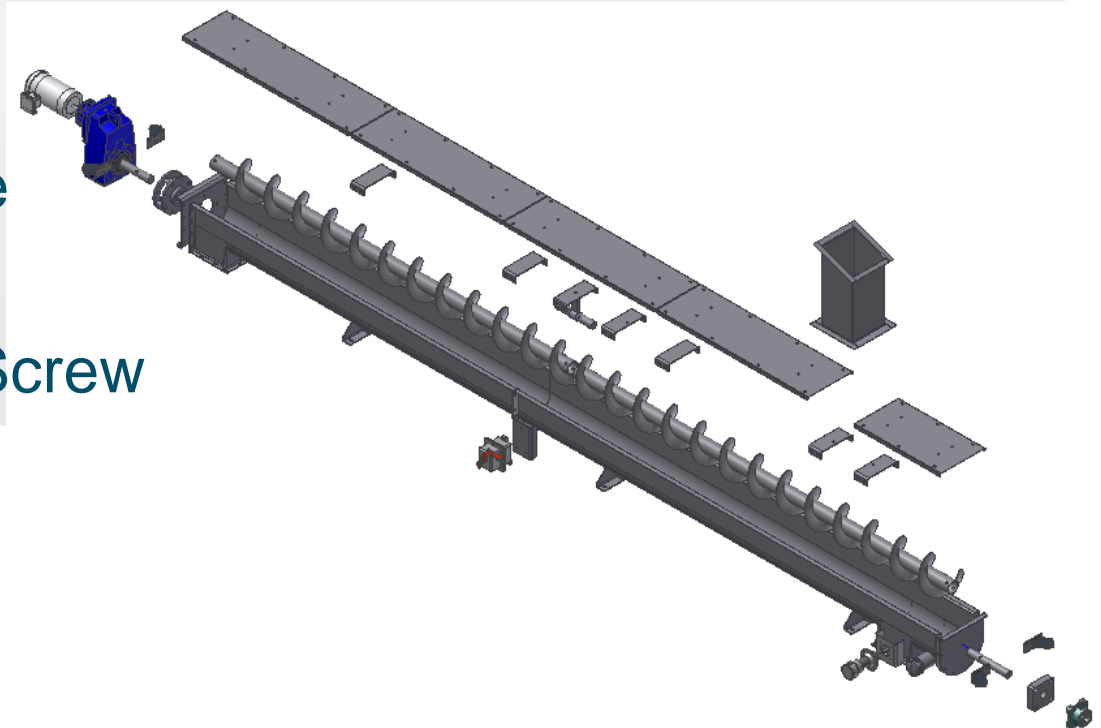



- Simple with few moving parts
- Completely Enclosed
- Long conveyors common
- No liners to change
- Low Cost

Shafted Basics

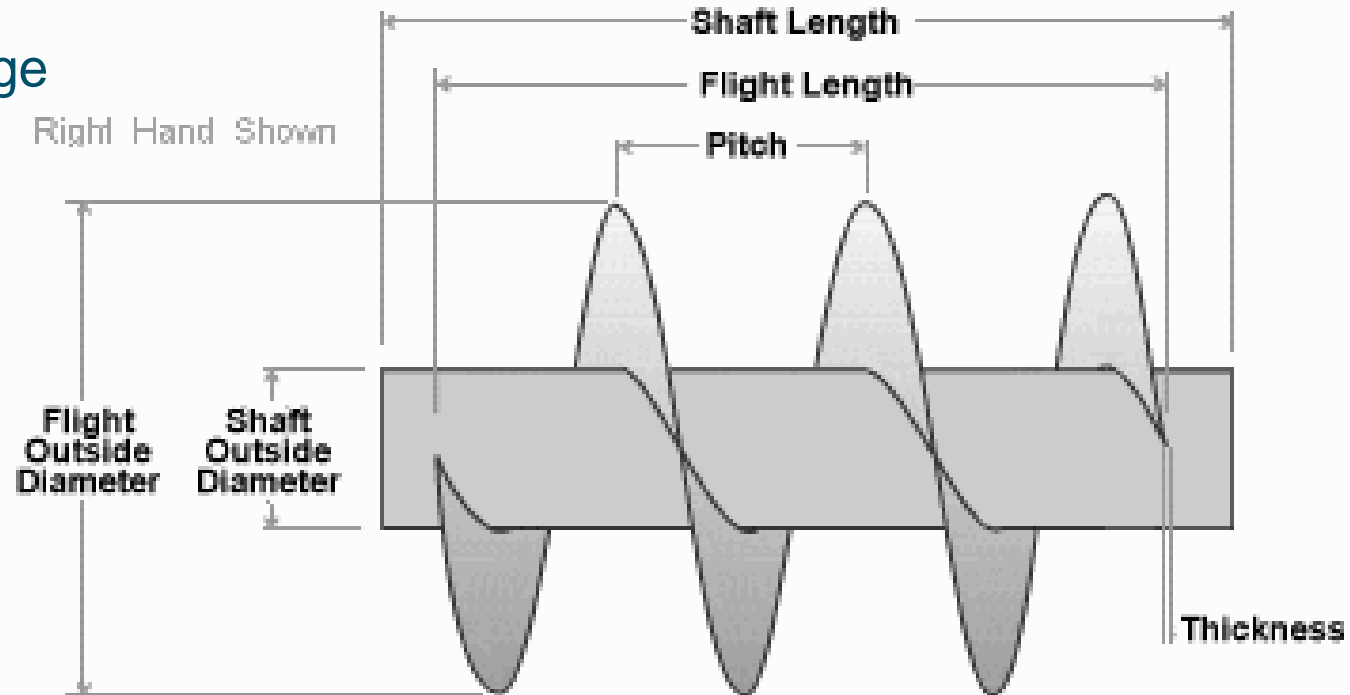



Shafted Trough Basics

Trough shapes

- U, Cylinder

Trough Sizes

- 4, 6, 8, 12, 14, 16, 18, 20, 24"

Trough Thicknesses

- 16 ga. 10 ga. 3/16" 1/4"

Cover Thickness

- 16 ga. 12 ga.

Pitch

- Full, 2/3, 1/2, others

Options

- Hinged covers
- Water Cooling
- Drive arrangements



Trough Loading	Screw Dia.	Max. RPM	Capacity in Cu.Ft./Hr.	
			At Max. RPM	At 1 RPM
15% Fill Rate	4	69	14.5	.21
	6	66	49.5	.75
	9	62	173	2.8
	10	60	222	3.7
	12	58	389	6.7
	14	56	588	10.5
	16	53	832	15.7
	18	50	1,135	22.7
	20	47	1,462	31.1
	24	42	2,293	54.6
30% Fill Rate	4	139	57	.41
	6	132	198	1.5
	9	122	683	5.6
	10	118	849	7.2
	12	111	1,476	13.3
	14	104	2,194	21.1
	16	97	3,046	31.4
	18	90	4,086	45.4
	20	82	5,092	62.1
	24	68	7,426	109.2



Conveyors Shafted Screw

Applications - Sludge Horizontal to Incline

Shown with Optional Sludge Storage Hopper

- Ideal for layouts that make it hard to replace shaftless liners.

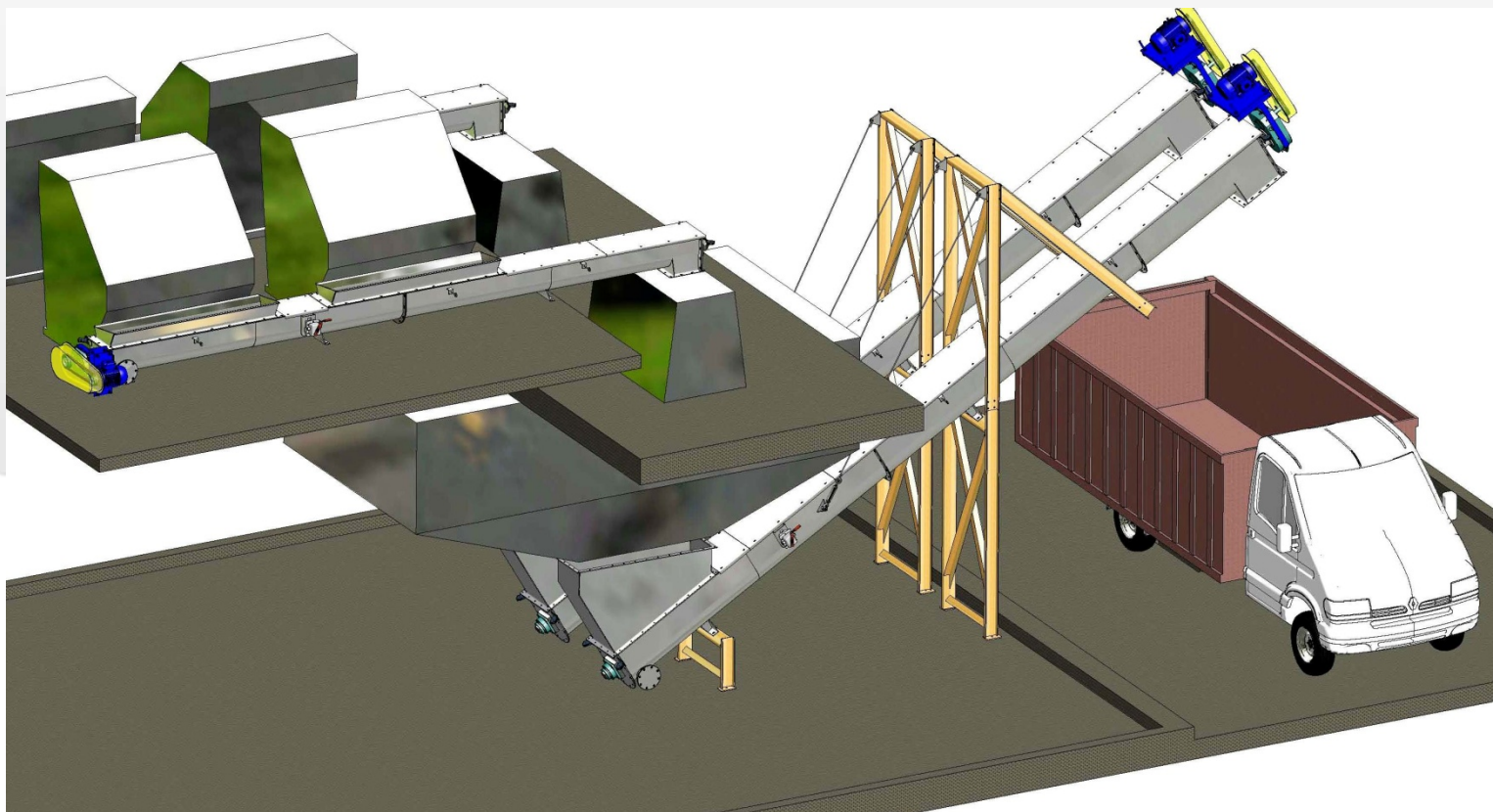



DISTRIBUTION

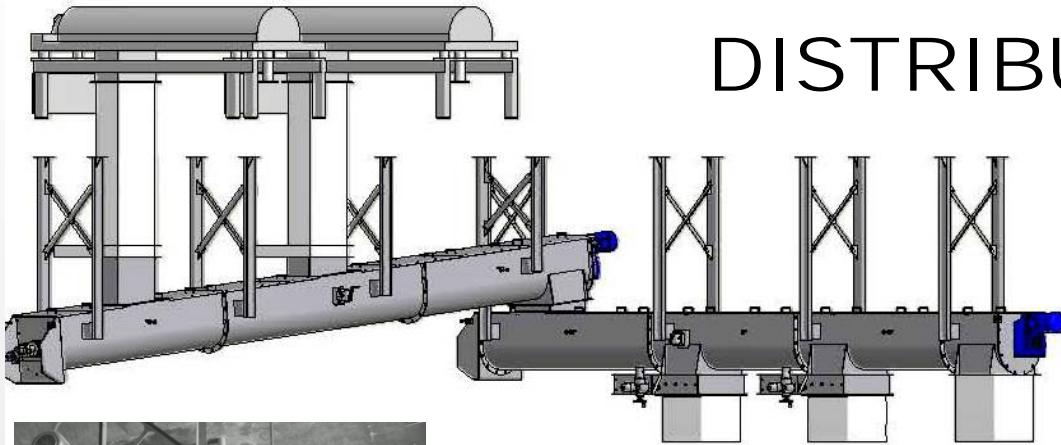

Truck or Bin Loading Systems

- Overhead supports and ceiling height often make replacing shaftless liners difficult.
- Slide Gates send sludge to the needed point of discharge.
- Gates may be actuated electrically, pneumatically or hydraulically.

Dewatered Sludge, North Oconee WRF, Athens, GA.



Custom Conveyor
Corporation

Conveyor
Value

Experience

Custom Conveyor Corp offers **30 years** experience manufacturing in our own fully equipped facility. We are the industry Leader with 3000 installations and 100 miles of conveyors uniquely offering Versatility of the **correct conveying solution** for your application -

Belt · Pneumatic · Shafted screw · Shaftless spiral

Quality

Custom Conveyor Corp **continuously invests** in the equipment and skilled staff for quality, product improvement and growth. We offer many proprietary conveyor components including radius formed trough tooling and the world's Highest quality Spirals

Reliability

Custom Conveyor Corp has thousands of trouble free installations.

Custom Conveyor Corp - The System Professionals
Your Total Material Handling Solutions Supplier