

**Model No.**

**- 8391 -**

**p/n 109165**



**KENAI**  
*Dave Grenz*

**Specifications**

- **Height - 62" (17" packed)**
- **Width - 35"**
- **Depth - 98" (59" packed)**
- **Weight - 50 lbs.**
- **Instructions - 103652**

**\*\*\*\*\* Warranty Information \*\*\*\*\***

**NOTICE!!! Please contact Clam Customer Service at the email address or phone number below for any quality issues..**

**\*\* Warranty cannot be honored without an original, dated receipt \*\***

**IMPORTANT - PLEASE READ:**

This product is warranted to the original retail purchaser (from an authorized dealer) and is non-transferable. Clam Corporation has a one year **manufacturer's defect warranty** from the date of original purchase. Warranty does not cover cracked or worn bases (if runner kits have not been installed as recommended), cracked windows, tent tears or cuts, or broken or bent hoops due to high wind weather conditions or unattended use. Defective parts will be replaced or repaired (at the manufacturer's option) if found to be defective within one (1) year from the date of original purchase. Warranty will be void if product has been subject to neglect, misuse, improper installation, misapplication, alteration, accident including but not limited to improper maintenance, or use of unauthorized parts or attachments. Please read the entire owner's manual to ensure proper installation, use, storage and care of your Clam Shelter.

**To submit a warranty claim request, please use one of the following methods:**

- **Email:** [CustomerService@ClamCorp.com](mailto:CustomerService@ClamCorp.com) (Preferred Method)
- **Fax:** 763-231-4121
- **Write:** Customer Service – Warranty Department  
12135 Brockton Lane N.  
Rogers, MN 55369

In your request, please include your full name, address, phone number, a copy of your receipt, a brief description of the problem, and pictures to clearly show the area(s) of concern. Our Warranty Department will review your request, and a Clam representative will contact you regarding your claim status. All returns must be shipped to us postage pre-prepaid. A customer service representative can be reached at 763-231-4120.

**- Limitation of Liability -**

***It is expressly understood that Clam Corporation's liability for its products, whether due to breach of warranty, negligence, strict liability, or otherwise, is limited to the repair of the product as stated above. Clam Corporation is not liable for any injury, loss, damage, or expense, whether direct or consequential, including but not limited to loss of use, income, profit, or damage to material arising in connection with the sale, installation, use of, inability to use, or the repair or replacement of Clam Corporation products. Clam Corporation reserves the right to make alterations or modifications in its products at any time, which in its opinion, may improve the performance and efficiency of the product. Clam shall not be obligated to make such alterations or modifications to products already in service.***

## - Parts List -

| ITEM NO. | PART NUMBER | DESCRIPTION              | QTY. |
|----------|-------------|--------------------------|------|
| 1        | 102716      | HOOP POLE, KENAI         | 3    |
| 2        | 102727      | BASE, KENAI              | 1    |
| 3        | 103650      | TENT, KENAI              | 1    |
| 4        | 103653      | BENCH SEAT ASSY          | 1    |
| 5        | 101082      | NUT, 1/4-20 THIN NYLOCK  | 20   |
| 6        | 101081      | WASHER, 1/4 FLAT         | 24   |
| 7        | 101208      | SCREW, 1/4-20 X 1-1/2"   | 12   |
| 8        | 101088      | SCREW, 1/4-20 X 0.75     | 10   |
| 9        | 101906      | SCREW, 1/4-20 X 2.50     | 2    |
| 10       | 101010      | TUBE SPACER CAP          | 6    |
| 11       | 101095      | ROPE, 3/8 DIA X 9 FT TOW | 1    |
| 12       | 102713      | SEAT BASE TUBE ASSY      | 1    |
| 13       | 102715      | 1" SQUARE TUBE PLUG      | 4    |
| 14       | 102748      | ADJUSTABLE SPREADER POLE | 1    |
| 15       | 101813      | RAIL HANGER BRACKET      | 2    |
| 16       | 102711      | SEAT TUBE                | 2    |
| 17       | 101148      | SCREW, #6 X 0.38         | 25   |
| 18       | 102717      | HOOP MOUNT BRACKET       | 2    |
| 19       | 102809      | MOLDING, KENAI           | 1    |
| 20       | 103652      | INSTRUCTION, KENAI       | 1    |

**PARTS**

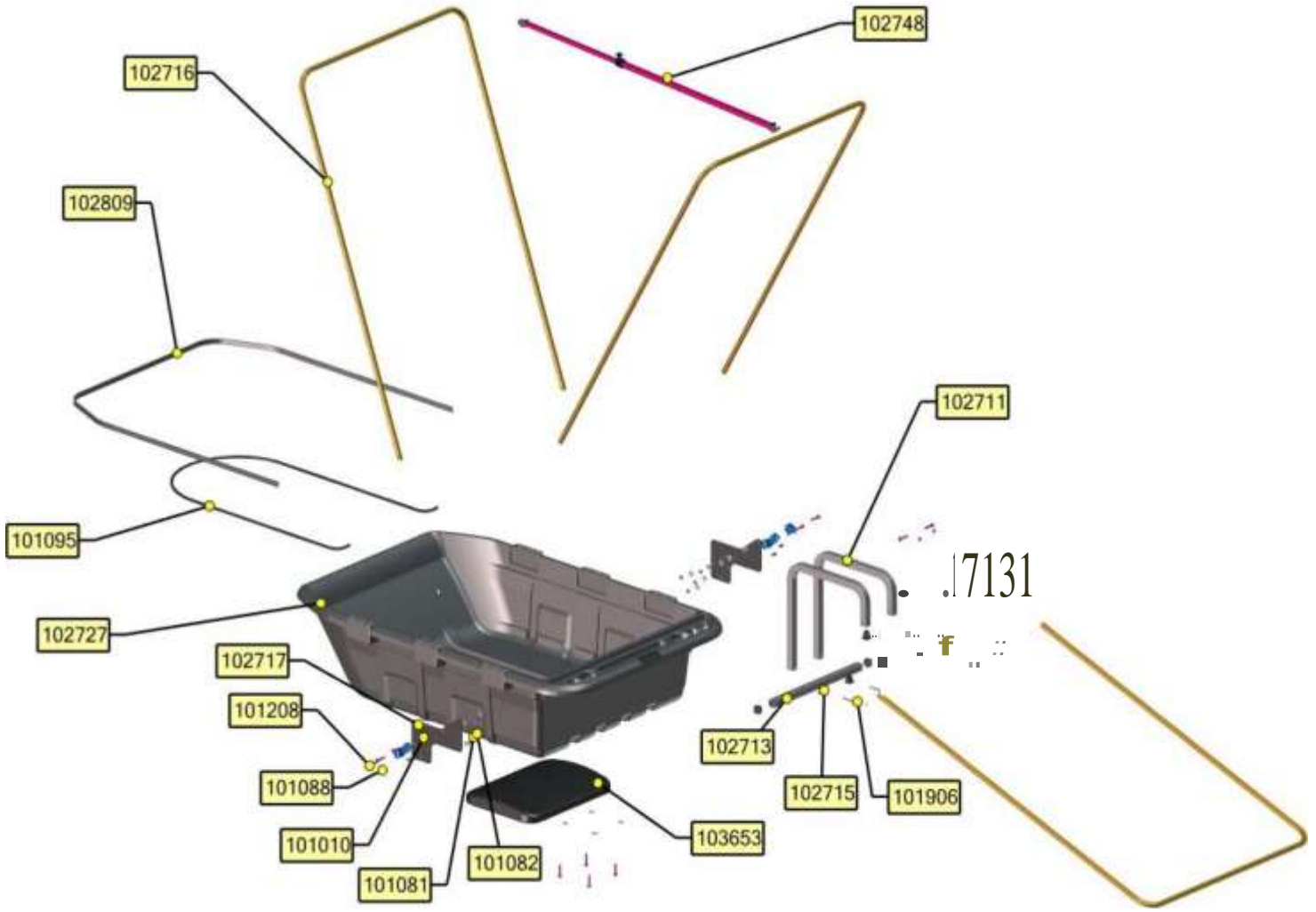

## STEP 1

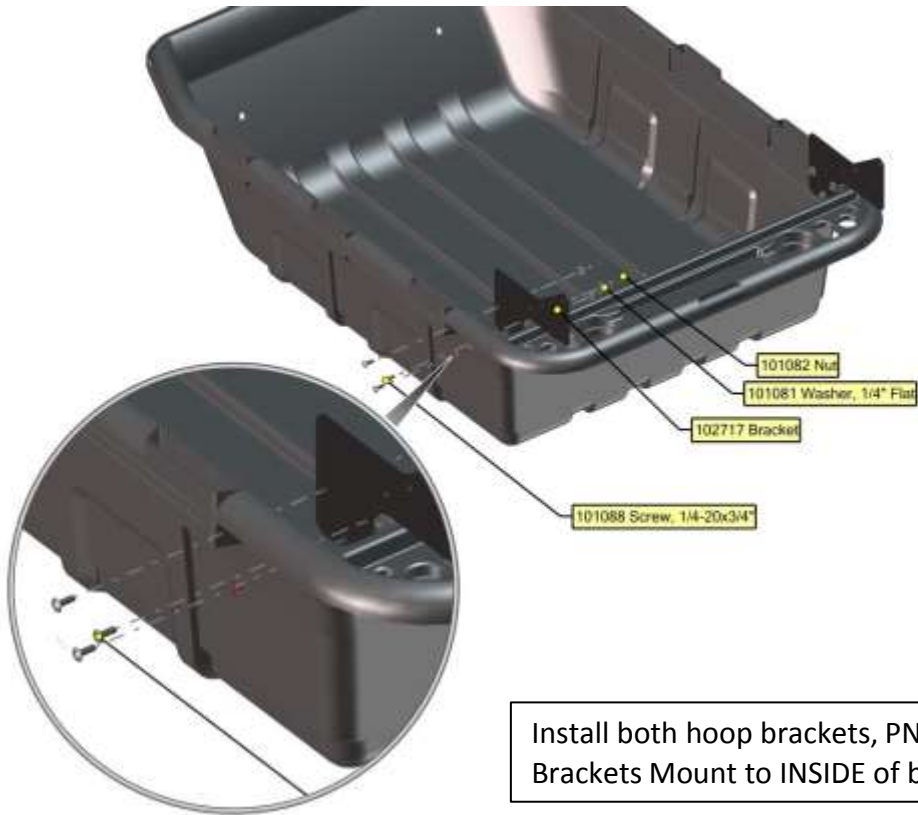

Install both hoop brackets, PN 102717.  
Brackets Mount to INSIDE of base.

## STEP 2

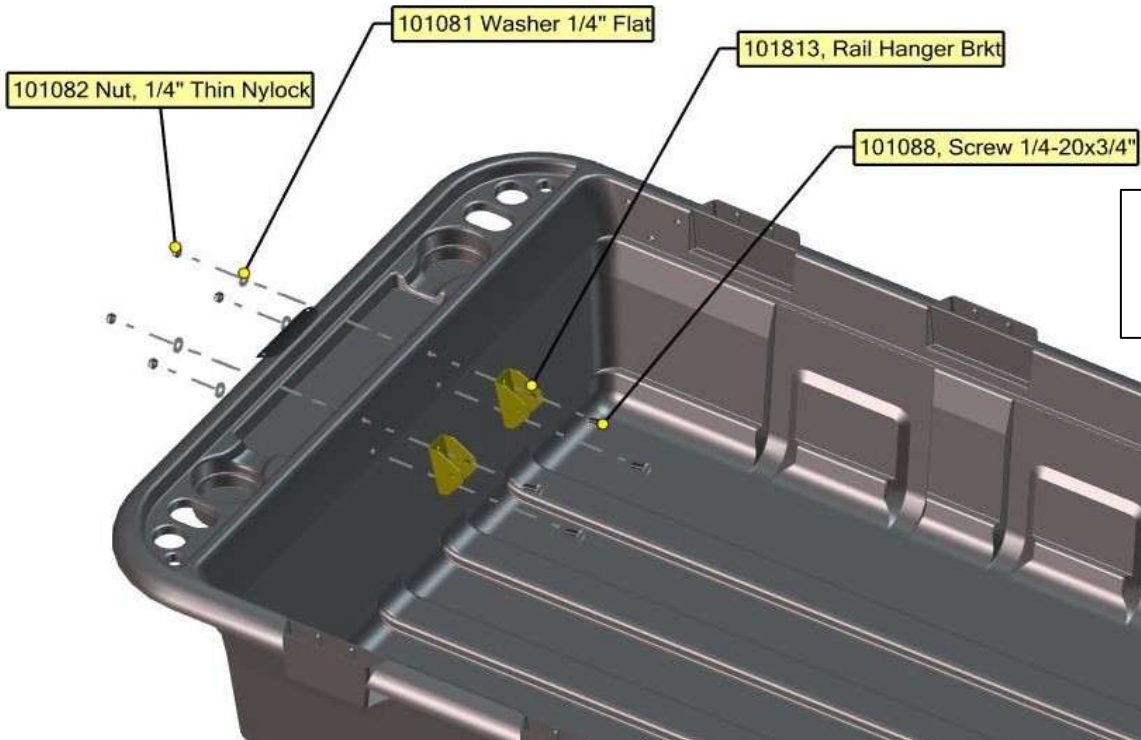

Install rail hanger  
brackets, PN  
101813 to base.

### STEP 3

Assemble seat tubes, PN 102711, install seat tube base, PN 102713, and bench seat, PN 103653.

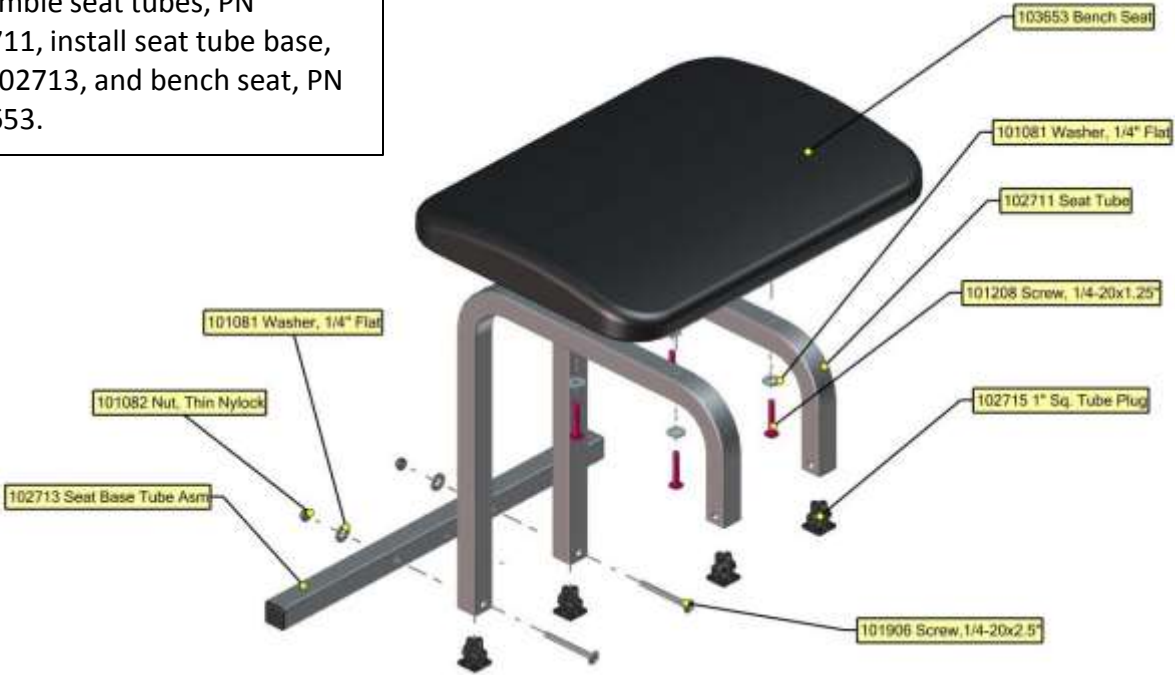

### STEP 4

Mount seat assembly to the rail hanger brackets.

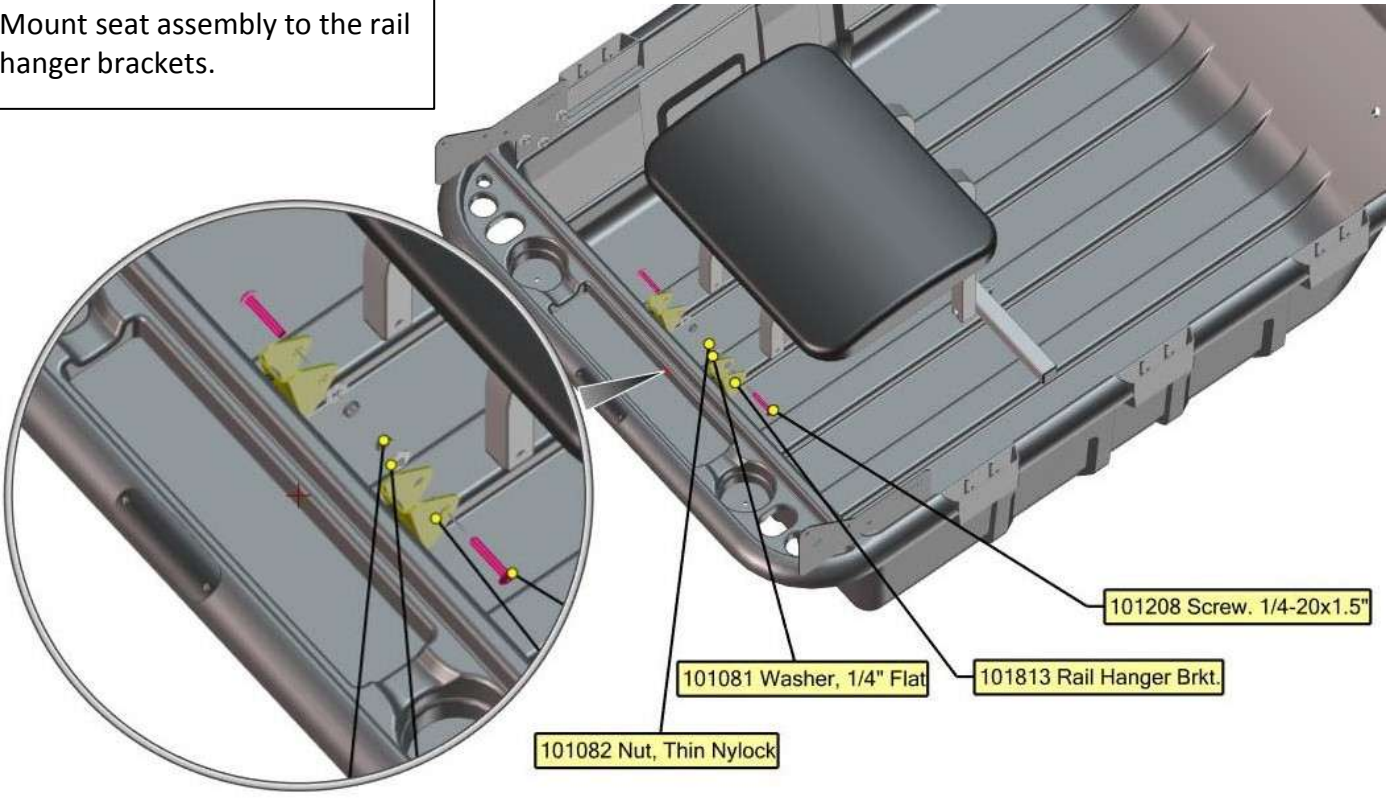

## STEP 5

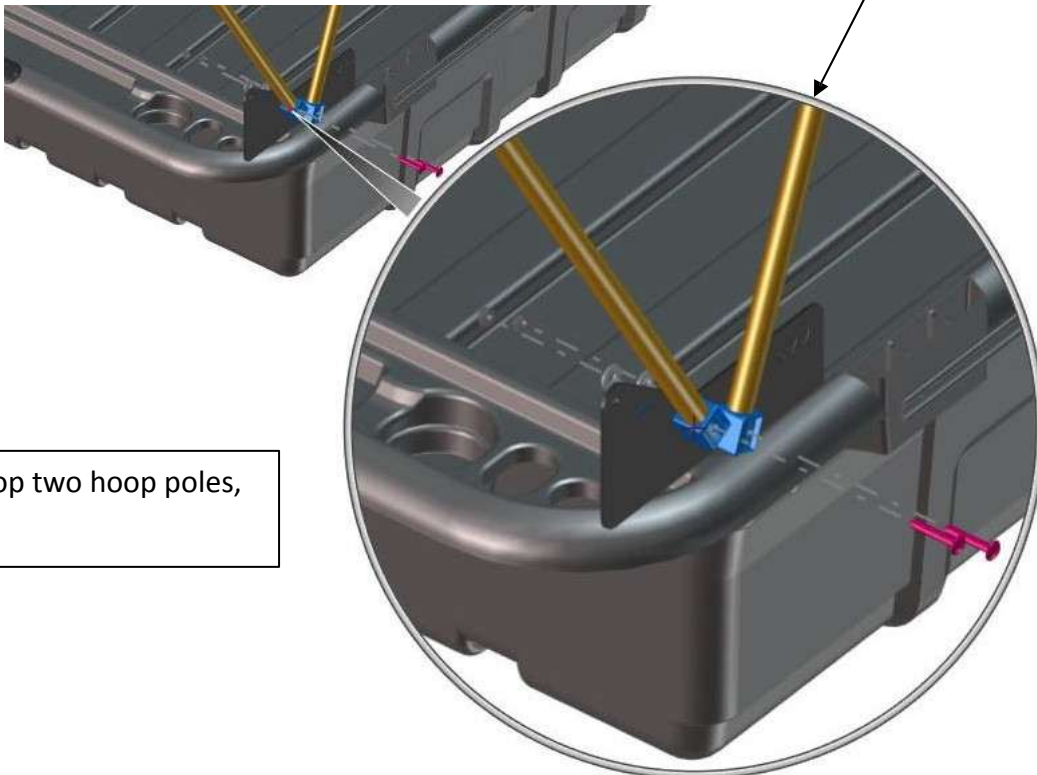
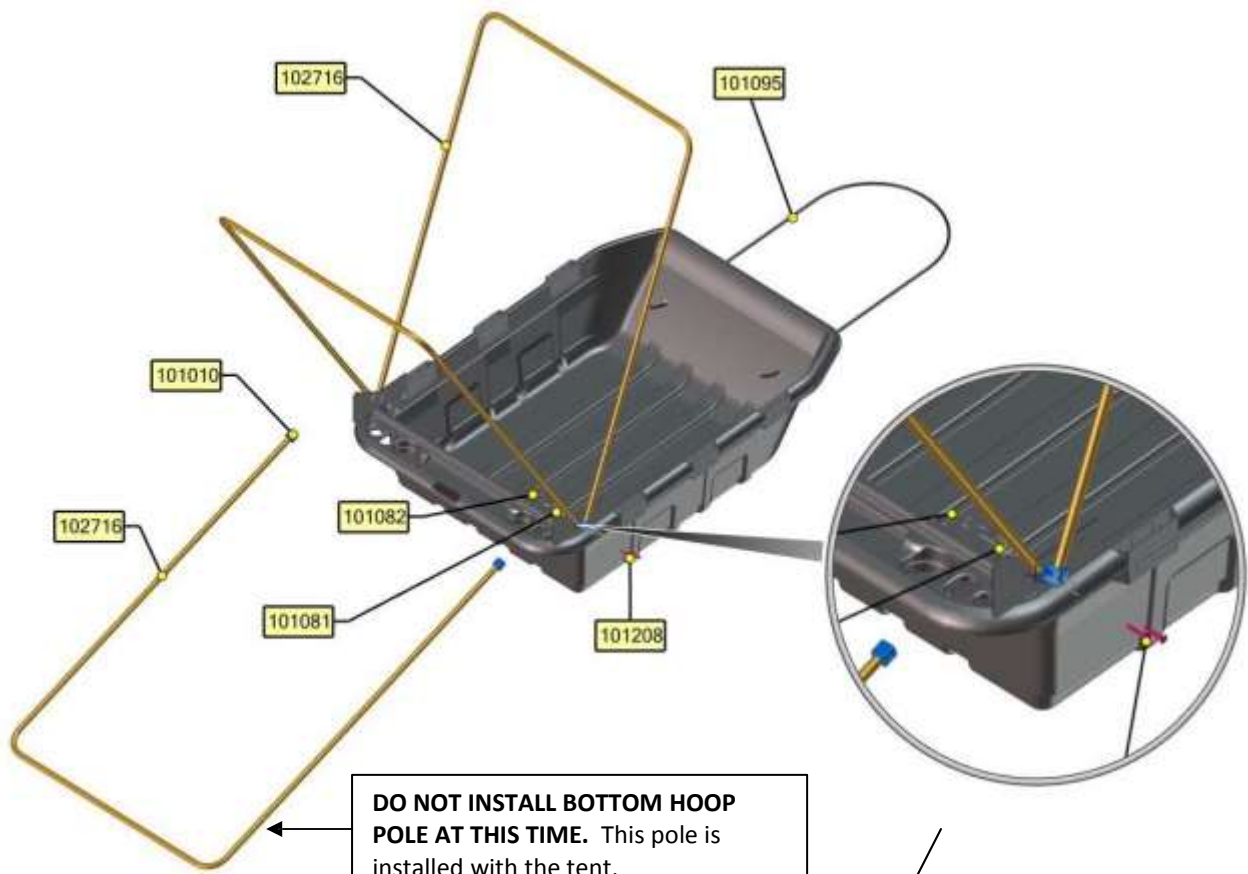

Install the top two hoop poles,  
PN 102716.

**STEP 6**

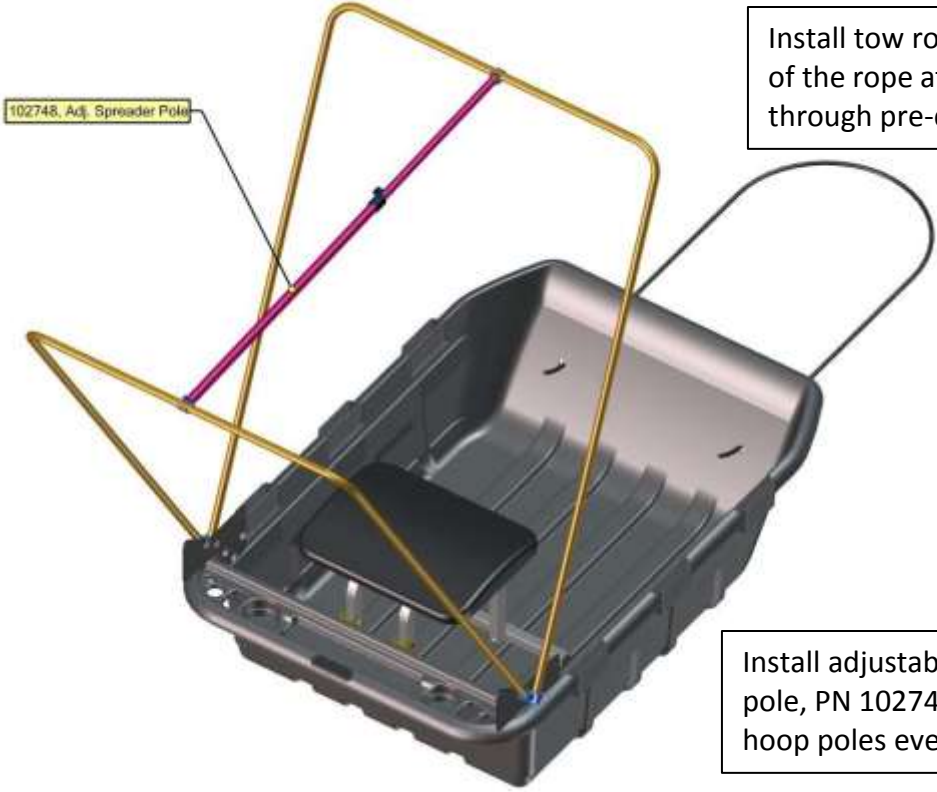

Install tow rope. Knot the ends of the rope after routing through pre-drilled holes.

Install adjustable spreader pole, PN 102748, spacing the hoop poles evenly apart.

**STEP 7**

Install Bottom Hoop Pole, PN 102716, through sleeve in tent.

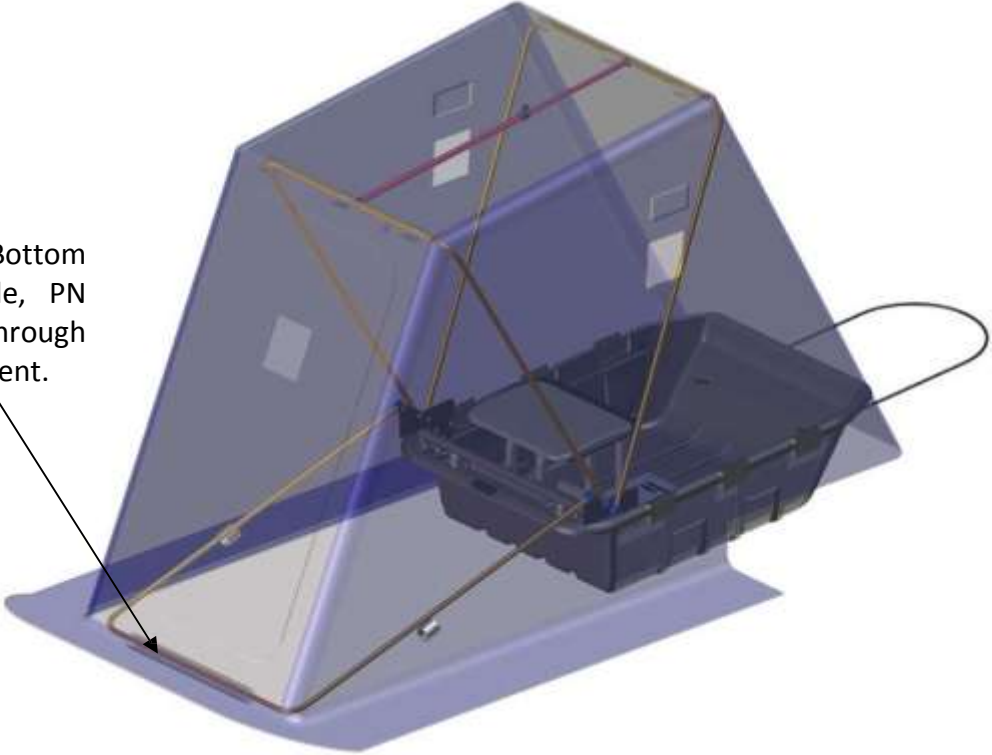

***Drape the tent over the supported hoops, then go inside and attach the roof Velcro straps.***

***Slide the remaining bottom hoop pole (PN 102716) through the hoop sleeves sewn on the tent.***

***Install the bottom hoop pole to the canopy brackets.***

***Attach the bottom hoop Velcro. Set the tent in the next step.***

## Step 8

To "set" the tent, grasp the tent material at the rear of the shelter and pull it downward. Observe the porch area of the tent lifting accordingly as you pull. When the molding, PN 102809 is correctly installed, the bottom hoop pole will lightly touch the floor.

From behind the unit, pull the midpoint of the tent downward until the bottom hoop pole just starts to come off the ground. Secure the tent in this position with a clamp. Continue stretching the tent around the base and secure with clamps.

Take a walk around the shelter to inspect. You may have to remove and readjust the clamps until you have verified the proper hoop pole position and also that the tent sides and corners are properly proportioned. It is also advised to sit in the seat prior to permanently attaching the tent to ensure that the front porch pole stays in the correct position when weight is added to the shelter seats & base.

When satisfied, apply the molding around the shelter, one direction from center and then the other, keeping the fabric relatively wrinkle-free and snug. Use a side-cutters to trim the ends of the molding if they are not equal relative to the base.

Evenly space the screws, PN 101148 about every four to six inches, and also put a screw in the center of both corners. There are no predrilled holes. We advise using a powered driver for this operation.

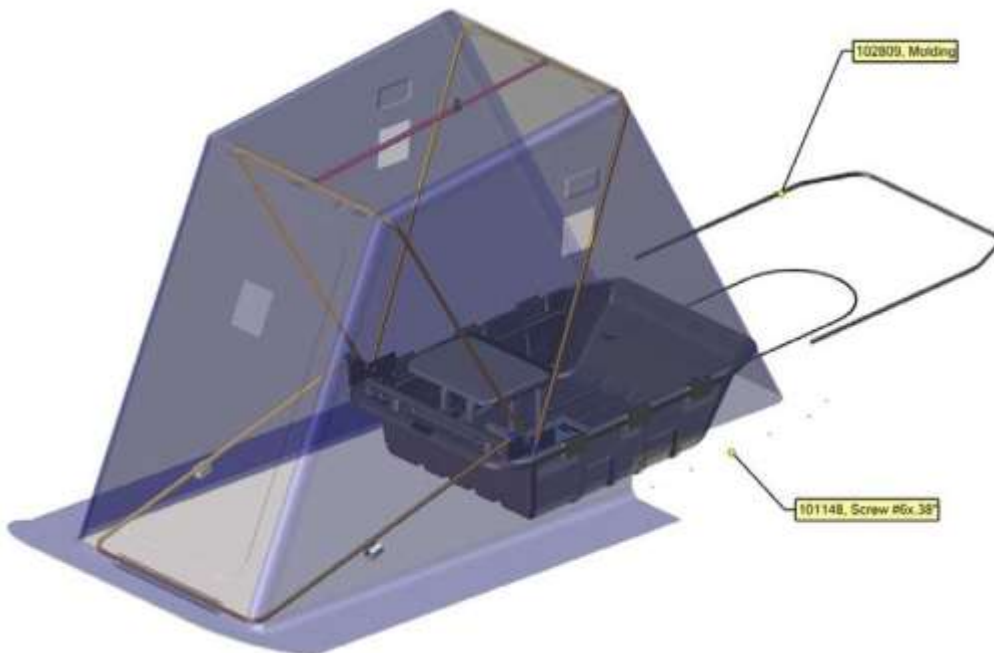



## - Tips for Use -

**Folding and transporting your Clam Ice Fishing shelter is easy:**

- **Unsnap the spreader pole and lay it in the bottom of the base.**
- **Fold all hoops to the resting position. Tuck the tent into the base and between the hoops so that no material is left hanging on the ground for transport.**
- **Cover with the Travel Cover\* (PN 109207-an optional but recommended accessory to help prolong the life of the unit).**
- **We recommend the optional Runner Kit\* (PN 108997) be mounted to the base of your shelter (NOTE: Pulling behind an ATV or snowmobile may result in premature wear of the base).**
- **In windy conditions it is advised to secure your shelter to the ice using Clam's Ice Anchor Kit (PN 108064) and Ice Anchor Installation Tool (PN 108348).**

**Make sure your ice shelter is completely dried out after each use. Store your Ice Shelter in a cool, dry place. Keep away from rodents.**

**\*For replacement parts, frequently asked questions, shelter information, and all of your ice fishing needs visit our web site at [www.clamoutdoors.com](http://www.clamoutdoors.com).**

## - Safety Instructions -

**Please fully understand and follow all safety instructions as outlined. Failure to do so could result in severe injury or death.**

- **Do not use open flame heaters in your ice shelter. Injury or death may result from fire if tent fabric is exposed to open flame. The tent is not fireproof, but the fabric is treated with a fire retardant that meets CPAI-84 specifications. Application of any foreign substance may render the flame retardant properties ineffective. Ice Armor fabric will melt when contact is made with hot surfaces (i.e., heaters).**
- **Death from asphyxiation may result from use of oxygen depleting heaters. Open all vents for fresh air ventilation.**
- **Never leave shelter unattended when set up.**
- **Due to the increase in traffic (snowmobiles, autos, etc.) on area lakes, ice fishing can be hazardous at night. If you choose to fish at night or in poor visibility conditions, be sure to take precautions with lights or reflectors to show drivers your location. Night time: exterior reflectors must be visible to reduce risk of collisions.**

### **WARNING**

Death from asphyxiation may result from use of oxygen depleting heaters. Open all vents for fresh air ventilation.

Injury or death may result from fire if tent fabric is exposed to open flame.

Tent fabric is not fireproof. Fabric will burn with extended exposure to open flame. Do not use open flame products inside tent. Tent fabric is treated with fire retardant. Application of any foreign substance may render the flame retardant properties ineffective.

Night time: exterior reflectors must be visible to reduce risk of collisions.

This tent is made with flame resistant fabric which meets CPAI-84 specifications.

# FREQUENTLY ASKED QUESTIONS

## Fish Trap FAQ's

Find parts and accessories at [www.clampoutdoors.com](http://www.clampoutdoors.com)

**Q: The zipper on my shelter freezes up and/or sticks. Is there anything I can use to help prevent this from happening?**

A: Yes, there are a couple of zipper lubricants available that our customers and pro staff have used with good results.

- Zipper Lube is one brand, often found in the camping section of sporting goods stores. This is a gel applied to the zipper.

- There are also a few silicone sprays that may be used to lubricate the zipper.

**Q: Are there replacement bases available for my Clam/Fish Trap?**

A: We have bases available for current shelters. If your shelter is an older model, we may not have the exact replacement for that shelter, but may have one that will work. Go to [www.clamoutdoors.com](http://www.clamoutdoors.com) or email Customer Service at [customerservice@clamcorp.com](mailto:customerservice@clamcorp.com)

**Q: What will help keep mice or rodents from eating the tent of my Clam or Fish Trap?**

A: We recommend that you keep your tent in a sealed plastic tote with laundry dryer sheets or moth balls. If the shelter is stored in a barn or shed take the tent off the house and store it in a rodent-free environment such as in your home.

**Q: I have lost the owner's manual for my shelter. Where can I get another one?**

A: There are owner's manuals available online at [www.clamoutdoors.com](http://www.clamoutdoors.com)

**Q: Do you have replacement tents for Clam and/or Fish Trap shelters that are a few years old?**

A: We have replacement tents available, but are limited on tents that are several seasons old. Go to our on-line store at [www.clamoutdoors.com](http://www.clamoutdoors.com)

**Q: The sliding seat poles, frame poles, or spreader poles of my shelter are sticking. Is there anything to put on these poles to help them slide better?**

A: Our pro staff and customers have used the following with good results.

- Zipper Lube, a gel, can be found in the camping section of your local sporting goods store. Apply the gel to the poles and use a rag to wipe off the excess.
- Car wax can be effective in helping to lubricate poles. Apply wax and rub well. Wipe off excess wax.
- When poles slide up and down against each other sometimes burrs are created. If this happens separate the affected poles and use a fine file or sand paper to deburr the pole(s) and then apply a thin coat of lubricant before rejoining the poles.

**Q: Must I put screws through the V-channel molding and canvas of my shelter?**

A: Yes, putting screws through the V-channel helps to securely fasten the tent of your shelter to the base. This is a necessary step for proper installation and failure to do so will void the warranty.

**Q: I am trying to attach the V-channel molding to my shelter, but am having difficulty getting it started, as it seems too stiff and will not stay attached to the edge of the sled. What can be done to help?**

A: It may be difficult to attach the V-channel in cold conditions. Assembly of the shelter should be done indoors with the V-channel warmed with a hair dryer, heat gun, or soak it in a bucket of hot water for several minutes so it will be more pliable.

**Q: I can see pinholes of light through the fabric of my tent. What can be done?**

A: IceArmor fabric is a woven material and these pin holes are part of the thread that the coating did not attach to. Also, sometimes more pinholes appear along seams, and are simply holes where the stitching is pulling the fabric. In either case, this has no effect on the function of the fabric and is simply an appearance issue.

**Q: There are cracks on the inside finish of the fabric of my shelter. Is this normal? Can anything be done to fix this?**

A: It is normal for some of the dark colored coating to come off the inside of the tent. Over time, as you set up and take down the shelter, the dark coating can begin to flake off, especially along the folds in the fabric when the shelter is collapsed. This does not affect the function of the fabric. If you feel that too much light is now entering your shelter in the places where some of the coating has come off, you may wish to apply a new layer of rubberized coating. A product you may use for this is Loctite Color Guard (black), available in liquid (paint-on) or aerosol form. The product number is LOC 34894. This is available at many hardware or home improvement stores.

**Q: Would it be best to completely dry out my shelter after every time it gets used?**

A: It is recommended that your tent be dried out completely after each use. If it is not dried out, moisture may cause some damage to the shelter. This is especially important if the shelter is to be stored for a long period of time.

**Q: I bought the correct travel cover for my Fish Trap or flipover style shelter, but it does not seem to fit properly. Is there a certain way the travel cover should be put on?**

A: The travel covers are custom made and most of them do need to be put on a certain way. If you are having trouble getting the cover on over the last corner, or if it seems too short, try rotating the cover 180 degrees and pull it over the collapsed shelter.

**Q: How do I wash the tent of my ice fishing shelter?**

A: We recommend that you use a mild bleach and water solution (1 part bleach to 10 parts water), or a mild soap

## FREQUENTLY ASKED QUESTIONS

detergent and water solution. This will help to get rid of mildew and odor in your tent. Be sure to dry the tent thoroughly.

Note: We do not recommend using a washing machine to wash your tent, as this may damage the tent.

**Q: Will my fish house leak because I see pinholes in the fabric?**

A: While the fabric of the tents on the shelters is water resistant it is not waterproof, so some water from rain or melting snow may come through your tent. It is good to have small holes in the fabric to allow vapors inside the shelter to escape.

**Q: Will using a heater help to eliminate or reduce water vapor and condensation in my shelter?**

A: No. A byproduct of burning propane is water. A bigger heater will produce more water vapor. Also, the colder the temperature the more condensation there will be inside the shelter.

**Q: Are tent patch kits available for my flipover style Fish Trap or Clam ice fishing shelter?**

A: Yes, patch kits are available for a wide range of shelters, and may be purchased at clamoutdoors.com

**Q: How do I apply the patch material?**

A: When applying a patch it works best to spray some adhesive (we recommend using 3M #77 or 3M #90 spray adhesive) on to both surfaces—the part of the tent where the patch is going to be applied and the patch itself. Wait until the adhesive begins to dry and becomes tacky, then place the patch on the tent, and they will stick together. (Note: Care should be taken to apply the patch evenly and smoothly, since wrinkles or uneven areas will be very difficult to correct once the two surfaces with the adhesive have come into contact with each other.)

**Q: Is there anything that can be applied to the outside of the tent to prevent water from coming through?**

A: There are products that can be applied to the outside of a tent that will make it more water repellent, such as Kiwi Camp Dry.

**Q: I have seen some flipover style shelters with a removable console. Where can I get one?**

A: This console now comes with a retractable leg, and can be purchased from our **online Store** at clamoutdoors.com.

**Q: I have a plastic C-clip connector on the poles of my Clam/Fish Trap that have broken. Are these clips available for purchase?**

A: These clips, called Quick Connects, may be purchased through our **online Store** at clamoutdoors.com.

**Q: What is the proper way to set up and take down my Fish Trap?**

**Q : Do you ship outside of the United States?**

A: We are only set up to ship warranty or replacement parts required to **MAINTAIN** a Clam shelter (tents, poles, parts, patch kits, etc.). No accessories – see a local dealer or an online dealer of Clam products. If the replacement parts are not warranty you will be charged for the product plus actual shipping charges. It will be the customer's responsibility to pay all importing costs (duties, taxes, etc) at the time the goods are delivered.

**Q: The poles to my Clam/Fish Trap have gotten bent out of place. Should I try to bend them back?**

A: It might be possible to bend the poles back into their proper place. If your bent pole is not creased lay it on a flat surface and bend it back into shape. If you need to order replacement poles you can do that on our **online Store** at clamoutdoors.com.